



# PPC

*Solutions to Mechanical Seal Problems*  
THROUGH INNOVATIVE ENGINEERING AND EXPERT TECHNICAL SERVICE

MECHANICAL SEALS

## 1500ERB ECONOMICAL ROTATING BELLOWS

- \* **POSITIVE PIN DRIVE**  
ELIMINATES DISTORTED AND OUT OF ROUND SLEEVES
- \* **SETTING THE SEAL IS AUTOMATIC**  
UTILIZING POSITIONING BUTTONS THAT DO NOT REQUIRE REMOVAL
- \* **TANGENTIAL FLUSHING**  
DIRECTS ABRASIVE PARTICLES AWAY FROM THE SEAL FACES
- \* **NO HANG-UPS, FRETTING, OR WEAR**  
TO THE SLEEVE BECAUSE THERE IS NO DYNAMIC O-RING
- \* **WELDED METAL BELLOWS**  
IS A NESTED, DOUBLE-RIPPLED DESIGN THAT:  
PROVIDES IMPROVED PRESSURE HANDLING.  
DISTRIBUTES FACE LOADING EVENLY.  
IS INHERENTLY BALANCED  
IS SELF CLEANING.

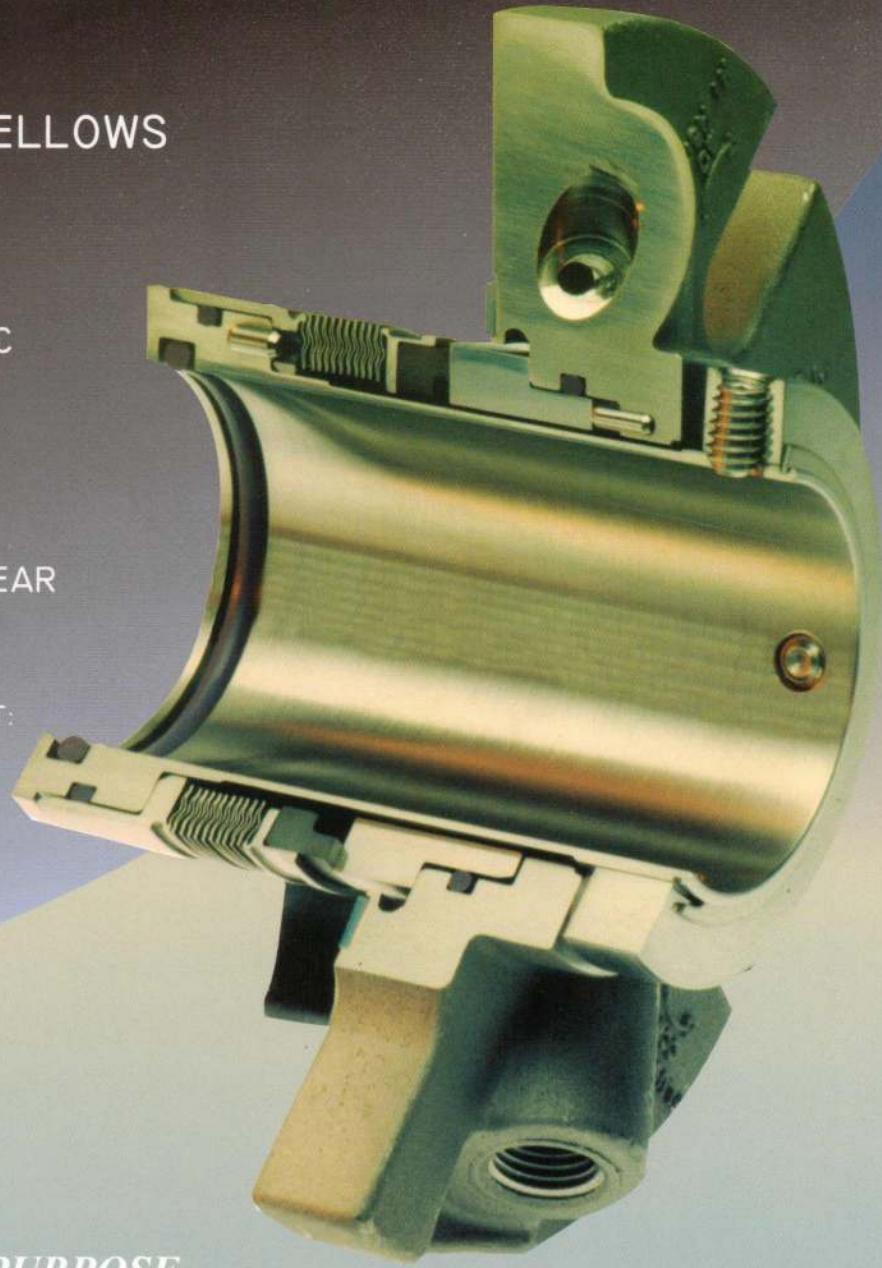

**PPC'S GENERAL PURPOSE  
CARTRIDGE METAL BELLOWS SEAL IN THE 1500E SERIES**

ON THE WEB @ [WWW.PPCMECHANICALSEALS.COM](http://WWW.PPCMECHANICALSEALS.COM)

### MATERIALS OF CONSTRUCTION

- METAL PARTS:** STAINLESS STEEL
- BELLOWS:** HASTELLOY C
- ELASTOMERS:** EP, FKM,  
PTFE ENCAPSULATED FKM,  
PERFLUOROELASTOMERS (FFKM)

### TECHNICAL DATA

- TEMPERATURES:** -20°F TO 400°F
- PRESSURE:** UP TO 300 PSIG,  
DEPENDING ON  
SHAFT SIZE & SPEED
- SPEED:** UP TO 4500 SFPM

### FACE COMBINATIONS:

- |                          |                                    |
|--------------------------|------------------------------------|
| <i>STATIONARY FACE</i>   | <i>ROTARY FACE</i>                 |
| SINTERED SILICON CARBIDE | CARBON OR SINTERED SILICON CARBIDE |

FOR OPERATING TEMPERATURES EXCEEDING 150°F, CONSULT YOUR PPC REPRESENTATIVE FOR ASSISTANCE.

**INSTALLATION INSTRUCTIONS:**  
 AFTER TIGHTENING GLAND BOLTS  
 PUSH SET SCREW COLLAR AGAINST  
 SETTING BUTTONS. THEN TIGHTEN  
 SET SCREWS.  
 SETTING BUTTONS ARE NOT REMOVED

\* .250 NPT FOR SEAL SIZES UP TO 2.625  
 .375 NPT FOR SEAL SIZES 2.750 AND ABOVE

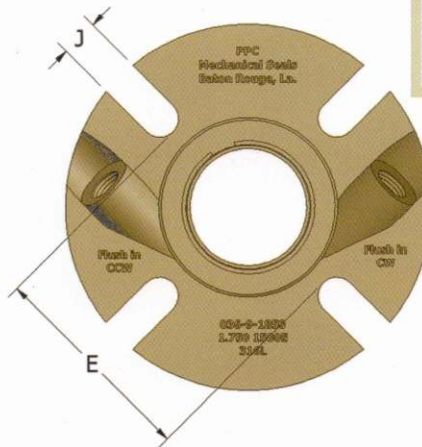
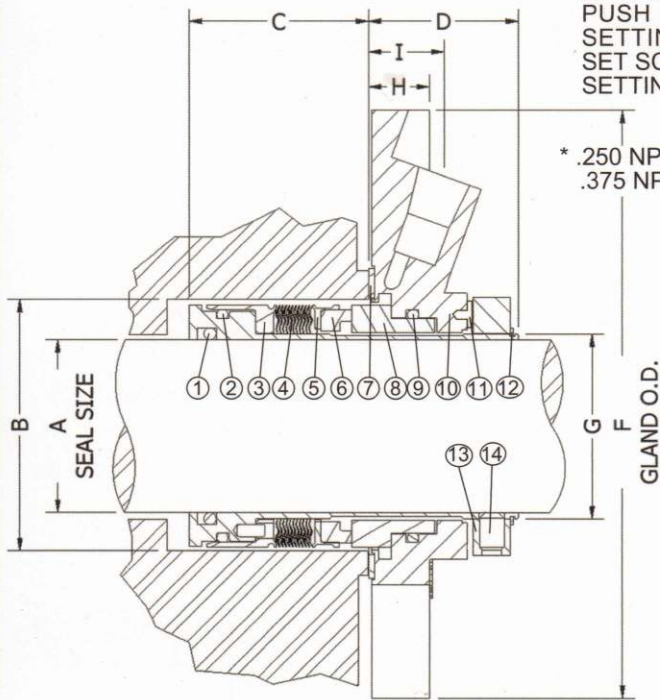

ITEM	DESCRIPTION
1	O-RING
2	O-RING
3	BELLOWS COLLAR
4	BELLOWS
5	INSERT HOLDER
6	INSERT
7	GASKET
8	STATIONARY FACE
9	O-RING
10	GLAND
11	SETTING BUTTONS
12	RETAINING RING
13	COLLAR
14	SET SCREWS

**I500ERB MECHANICAL SEAL ASSEMBLY**

A: SEAL SIZE	B MIN	B MAX	C	D	E	F	G	H	I	J
1.125	1.750	2.040	1.79	1.50	2.44	4.24	1.250	.98	.71	.44
1.250	2.000	2.270	1.79	1.50	2.69	4.36	1.375	.98	.71	.56
1.375	2.000	2.430	1.79	1.50	2.75	4.36	1.500	.98	.71	.44
1.500	2.250	2.630	1.79	1.50	2.94	4.99	1.625	.98	.71	.56
1.625	2.375	2.690	1.79	1.50	3.06	4.99	1.750	.98	.71	.56
1.750	2.500	2.810	1.79	1.50	3.19	5.48	1.875	.98	.71	.56
1.875	2.625	2.940	1.79	1.50	3.31	5.49	2.000	.98	.71	.56
2.000	2.750	3.190	1.79	1.50	3.44	5.49	2.125	.98	.71	.56
2.125	2.875	3.440	1.79	1.50	3.81	5.99	2.250	.98	.71	.69
2.250	3.000	3.560	1.79	1.50	3.94	6.24	2.375	.98	.71	.69
2.375	3.250	3.590	1.79	1.50	4.06	6.24	2.500	.98	.71	.69
2.500	3.375	3.810	1.79	1.50	4.19	6.48	2.625	.98	.71	.69
2.625	3.500	4.070	1.79	1.50	4.75	7.62	2.750	.98	.71	.69
2.750	3.812	4.190	2.14	1.80	4.88	7.74	3.000	1.20	.83	.69
3.000	4.062	4.440	2.14	1.80	5.06	8.00	3.250	1.20	.83	.69
3.250	4.312	4.690	2.14	1.80	5.38	8.25	3.500	1.20	.83	.69
3.500	4.562	4.940	2.14	1.80	5.62	8.50	3.750	1.20	.83	.81
3.750	4.812	5.190	2.14	1.80	5.88	8.75	4.000	1.20	.83	.81

**I500ERB+ MECHANICAL SEAL ASSEMBLY FOR OVERSIZE STUFFING BOX**

A: SEAL SIZE	B MIN	B MAX	C	D	E	F	G	H	I	J
1.125+	2.500	2.906	1.79	1.50	3.31	4.62	1.250	.98	.71	.44
1.375+	2.781	3.219	1.79	1.50	3.53	5.31	1.500	.98	.71	.44
1.750+	3.469	4.188	1.79	1.50	4.50	6.31	1.875	.98	.71	.56
1.875+	3.406	4.062	1.79	1.50	4.41	6.25	2.000	.98	.71	.56
2.500+	4.156	5.187	1.79	1.50	5.44	7.88	2.625	.98	.71	.69
2.625+	4.156	4.812	1.79	1.50	5.44	7.50	2.750	.98	.71	.56

**WARRANTY**

PPC SEALS AND SEAL PARTS ARE GUARANTEED TO BE FREE FROM DEFECTS IN MATERIAL AND WORKMANSHIP AND ARE GUARANTEED TO RENDER SATISFACTORY SERVICE WHEN USED FOR THE PURPOSE FOR WHICH THEY ARE DESIGNED.



MECHANICAL SEALS

P.O. BOX 52915 - 2769 MISSION DRIVE

BATON ROUGE, LA 70805

225-356-4333 - 1-800-731-7325 - FAX 225-355-2126

WWW.PPCMECHANICALSEALS.COM