

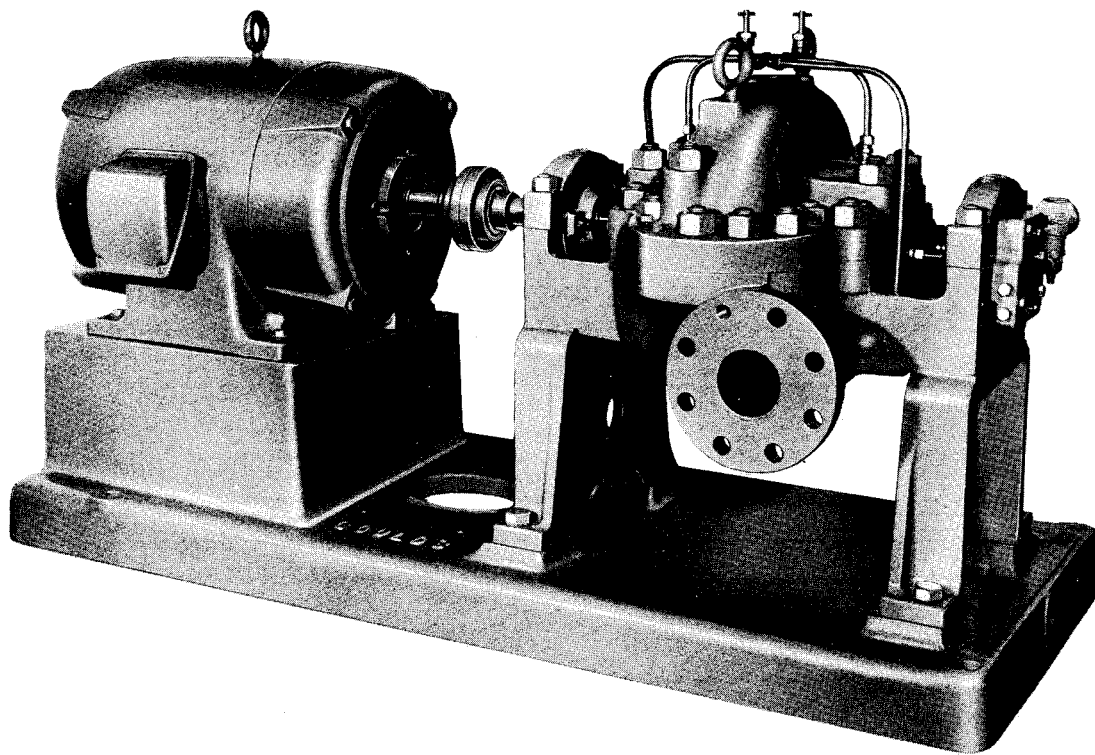

GOULDS PUMPS

Installation, Operation and Maintenance Instructions

MODEL 3316



ITT

IMPORTANT SAFETY NOTICE

To: Our Valued Customers

User safety is a major focus in the design of our products. Following the precautions outlined in this manual will minimize your risk of injury.

ITT Goulds pumps will provide safe, trouble-free service when properly installed, maintained, and operated.

Safe installation, operation, and maintenance of ITT Goulds Pumps equipment are an essential end user responsibility. This *Pump Safety Manual* identifies specific safety risks that must be considered at all times during product life. Understanding and adhering to these safety warnings is mandatory to ensure personnel, property, and/or the environment will not be harmed. Adherence to these warnings alone, however, is not sufficient — it is anticipated that the end user will also comply with industry and corporate safety standards. Identifying and eliminating unsafe installation, operating and maintenance practices is the responsibility of all individuals involved in the installation, operation, and maintenance of industrial equipment.

Please take the time to review and understand the safe installation, operation, and maintenance guidelines outlined in this Pump Safety Manual and the Instruction, Operation, and Maintenance (IOM) manual. Current manuals are available at www.gouldspumps.com/literature_ioms.html or by contacting your nearest Goulds Pumps sales representative.

These manuals must be read and understood before installation and start-up.

For additional information, contact your nearest Goulds Pumps sales representative or visit our Web site at www.gouldspumps.com.

SAFETY WARNINGS

Specific to pumping equipment, significant risks bear reinforcement above and beyond normal safety precautions.

 **WARNING**

A pump is a pressure vessel with rotating parts that can be hazardous. Any pressure vessel can explode, rupture, or discharge its contents if sufficiently over pressurized causing death, personal injury, property damage, and/or damage to the environment. All necessary measures must be taken to ensure over pressurization does not occur.

 **WARNING**

Operation of any pumping system with a blocked suction and discharge must be avoided in all cases. Operation, even for a brief period under these conditions, can cause superheating of enclosed pumpage and result in a violent explosion. All necessary measures must be taken by the end user to ensure this condition is avoided.

 **WARNING**

The pump may handle hazardous and/or toxic fluids. Care must be taken to identify the contents of the pump and eliminate the possibility of exposure, particularly if hazardous and/or toxic. Potential hazards include, but are not limited to, high temperature, flammable, acidic, caustic, explosive, and other risks.

 **WARNING**

Pumping equipment Instruction, Operation, and Maintenance manuals clearly identify accepted methods for disassembling pumping units. These methods must be adhered to. Specifically, applying heat to impellers and/or impeller retaining devices to aid in their removal is strictly forbidden. Trapped liquid can rapidly expand and result in a violent explosion and injury.

ITT Goulds Pumps will not accept responsibility for physical injury, damage, or delays caused by a failure to observe the instructions for installation, operation, and maintenance contained in this Pump Safety Manual or the current IOM available at www.gouldspumps.com/literature.

SAFETY

DEFINITIONS

Throughout this manual the words **WARNING**, **CAUTION**, **ELECTRICAL**, and **ATEX** are used to indicate where special operator attention is required.

Observe all Cautions and Warnings highlighted in this Pump Safety Manual and the IOM provided with your equipment.



WARNING

Indicates a hazardous situation which, if not avoided, could result in death or serious injury.

Example: Pump shall never be operated without coupling guard installed correctly.



CAUTION

Indicates a hazardous situation which, if not avoided, could result in minor or moderate injury.

Example: Throttling flow from the suction side may cause cavitation and pump damage.



ELECTRICAL HAZARD

Indicates the possibility of electrical risks if directions are not followed.

Example: Lock out driver power to prevent electric shock, accidental start-up, and physical injury.









When installed in potentially explosive atmospheres, the instructions that follow the Ex symbol must be followed. Personal injury and/or equipment damage may occur if these instructions are not followed. If there is any question regarding these requirements or if the equipment is to be modified, please contact an ITT Goulds Pumps representative before proceeding.













Example:  Improper impeller adjustment could cause contact between the rotating and stationary parts, resulting in a spark and heat generation.



GENERAL PRECAUTIONS

WARNING

A pump is a pressure vessel with rotating parts that can be hazardous. Hazardous fluids may be contained by the pump including high temperature, flammable, acidic, caustic, explosive, and other risks. Operators and maintenance personnel must realize this and follow safety measures. Personal injuries will result if procedures outlined in this manual are not followed. ITT Goulds Pumps will not accept responsibility for physical injury, damage or delays caused by a failure to observe the instructions in this manual and the IOM provided with your equipment.

General Precautions		
WARNING		NEVER APPLY HEAT TO REMOVE IMPELLER. It may explode due to trapped liquid.
WARNING		NEVER use heat to disassemble pump due to risk of explosion from tapped liquid.
WARNING		NEVER operate pump without coupling guard correctly installed.
WARNING		NEVER run pump below recommended minimum flow when dry, or without prime.
WARNING		ALWAYS lock out power to the driver before performing pump maintenance.
WARNING		NEVER operate pump without safety devices installed.
WARNING		NEVER operate pump with discharge valve closed.
WARNING		NEVER operate pump with suction valve closed.
WARNING		DO NOT change service application without approval of an authorized ITT Goulds Pumps representative.
WARNING		<p>Safety Apparel:</p> <ul style="list-style-type: none"> ♦ Insulated work gloves when handling hot bearings or using bearing heater ♦ Heavy work gloves when handling parts with sharp edges, especially impellers ♦ Safety glasses (with side shields) for eye protection ♦ Steel-toed shoes for foot protection when handling parts, heavy tools, etc. ♦ Other personal protective equipment to protect against hazardous/toxic fluids
WARNING		<p>Receiving:</p> <p>Assembled pumping units and their components are heavy. Failure to properly lift and support equipment can result in serious physical injury and/or equipment damage. Lift equipment only at specifically identified lifting points or as instructed in the current IOM. Current manuals are available at www.gouldspumps.com/literature_ioms.html or from your local ITT Goulds Pumps sales representative. Note: Lifting devices (eyebolts, slings, spreaders, etc.) must be rated, selected, and used for the entire load being lifted.</p>
WARNING		<p>Alignment:</p> <p>Shaft alignment procedures must be followed to prevent catastrophic failure of drive components or unintended contact of rotating parts. Follow coupling manufacturer's coupling installation and operation procedures.</p>

General Precautions		
WARNING		Before beginning any alignment procedure, make sure driver power is locked out. Failure to lock out driver power will result in serious physical injury.
CAUTION		Piping: Never draw piping into place by forcing at the flanged connections of the pump. This may impose dangerous strains on the unit and cause misalignment between pump and driver. Pipe strain will adversely effect the operation of the pump resulting in physical injury and damage to the equipment.
WARNING		Flanged Connections: Use only fasteners of the proper size and material.
WARNING		Replace all corroded fasteners.
WARNING		Ensure all fasteners are properly tightened and there are no missing fasteners.
WARNING		Startup and Operation: When installing in a potentially explosive environment, please ensure that the motor is properly certified.
WARNING		Operating pump in reverse rotation may result in contact of metal parts, heat generation, and breach of containment.
WARNING		Lock out driver power to prevent accidental start-up and physical injury.
WARNING		The impeller clearance setting procedure must be followed. Improperly setting the clearance or not following any of the proper procedures can result in sparks, unexpected heat generation and equipment damage.
WARNING		If using a cartridge mechanical seal, the centering clips must be installed and set screws loosened prior to setting impeller clearance. Failure to do so could result in sparks, heat generation, and mechanical seal damage.
WARNING		The coupling used in an ATEX classified environment must be properly certified and must be constructed from a non-sparking material.
WARNING		Never operate a pump without coupling guard properly installed. Personal injury will occur if pump is run without coupling guard.
WARNING		Make sure to properly lubricate the bearings. Failure to do so may result in excess heat generation, sparks, and / or premature failure.
CAUTION		The mechanical seal used in an ATEX classified environment must be properly certified. Prior to start up, ensure all points of potential leakage of process fluid to the work environment are closed.
CAUTION		Never operate the pump without liquid supplied to mechanical seal. Running a mechanical seal dry, even for a few seconds, can cause seal damage and must be avoided. Physical injury can occur if mechanical seal fails.
WARNING		Never attempt to replace packing until the driver is properly locked out and the coupling spacer is removed.
WARNING		Dynamic seals are not allowed in an ATEX classified environment.
WARNING		DO NOT operate pump below minimum rated flows or with suction and/or discharge valve closed. These conditions may create an explosive hazard due to vaporization of pumpage and can quickly lead to pump failure and physical injury.

General Precautions		
WARNING		Ensure pump is isolated from system and pressure is relieved before disassembling pump, removing plugs, opening vent or drain valves, or disconnecting piping.
WARNING		Shutdown, Disassembly, and Reassembly: Pump components can be heavy. Proper methods of lifting must be employed to avoid physical injury and/or equipment damage. Steel toed shoes must be worn at all times.
WARNING		The pump may handle hazardous and/or toxic fluids. Observe proper decontamination procedures. Proper personal protective equipment should be worn. Precautions must be taken to prevent physical injury. Pumpage must be handled and disposed of in conformance with applicable environmental regulations.
WARNING		Operator must be aware of pumpage and safety precautions to prevent physical injury.
WARNING		Lock out driver power to prevent accidental startup and physical injury.
CAUTION		Allow all system and pump components to cool before handling them to prevent physical injury.
CAUTION		If pump is a Model NM3171, NM3196, 3198, 3298, V3298, SP3298, 4150, 4550, or 3107, there may be a risk of static electric discharge from plastic parts that are not properly grounded. If pumped fluid is non-conductive, pump should be drained and flushed with a conductive fluid under conditions that will not allow for a spark to be released to the atmosphere.
WARNING		Never apply heat to remove an impeller. The use of heat may cause an explosion due to trapped fluid, resulting in severe physical injury and property damage.
CAUTION		Wear heavy work gloves when handling impellers as sharp edges may cause physical injury.
CAUTION		Wear insulated gloves when using a bearing heater. Bearings will get hot and can cause physical injury.

ATEX CONSIDERATIONS and INTENDED USE

Special care must be taken in potentially explosive environments to ensure that the equipment is properly maintained. This includes but is not limited to:

1. Monitoring the pump frame and liquid end temperature.
2. Maintaining proper bearing lubrication.
3. Ensuring that the pump is operated in the intended hydraulic range.

The ATEX conformance is only applicable when the pump unit is operated within its intended use. Operating, installing or maintaining the pump unit in any way that is not covered in the Instruction, Operation, and Maintenance manual (IOM) can cause serious personal injury or damage to the equipment. This includes any modification to the equipment or use of parts not provided by ITT Goulds Pumps. If there is any question regarding the intended use of the equipment, please contact an ITT Goulds representative before proceeding. Current IOMs are available at www.gouldspumps.com/literature_ioms.html or from your local ITT Goulds Pumps Sales representative.

All pumping unit (pump, seal, coupling, motor and pump accessories) certified for use in an ATEX classified environment, are identified by an ATEX tag secured to the pump or the baseplate on which it is mounted. A typical tag would look like this:



The CE and the Ex designate the ATEX compliance. The code directly below these symbols reads as follows:

- II = Group 2
- 2 = Category 2
- G/D = Gas and Dust present
- T4 = Temperature class, can be T1 to T6 (see Table 1)

Code	Max permissible surface temperature °F (°C)	Max permissible liquid temperature °F (°C)
T1	842 (450)	700 (372)
T2	572 (300)	530 (277)
T3	392 (200)	350 (177)
T4	275 (135)	235 (113)
T5	212 (100)	Option not available
T6	185 (85)	Option not available

The code classification marked on the equipment must be in accordance with the specified area where the equipment will be installed. If it is not, do not operate the equipment and contact your ITT Goulds Pumps sales representative before proceeding.

PARTS

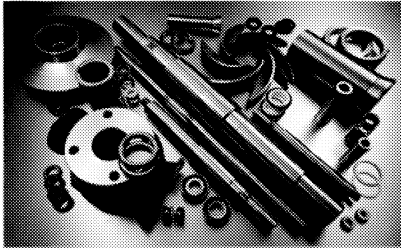

The use of genuine Goulds parts will provide the safest and most reliable operation of your pump. ITT Goulds Pumps ISO certification and quality control procedures ensure the parts are manufactured to the highest quality and safety levels.

Please contact your local Goulds representative for details on genuine Goulds parts.

Foreword

The design, material and workmanship incorporated in the construction of Goulds Model 3316 Multi-Stage Centrifugal Pumps make them capable of giving long, trouble-free service. The life and satisfactory service of any mechanical unit, however, is enhanced and extended by correct application, proper installation, periodic inspection and maintenance. This instruction book was prepared so operators will understand the construction and correct methods for installing, operating and maintaining these pumps.

Read thoroughly Section I, II, III, and IV and be sure to follow the instructions for installation and operation. Sections V and VI are answers to trouble and maintenance questions. Keep this instruction book handy for reference. Kindly direct any questions or suggestions to the attention of the Application Engineering Division, Goulds Pumps, Inc., Seneca Falls, New York.

Table of Contents

SECTION I — INSTALLATION		PAGE			PAGE
I-A	Location of Pumping Unit	1	IV-C	Operating at Reduced Head . .	10
I-B	Foundation	1	IV-D	Operating with Surge Condi- tions in Line	10
I-C	Alignment—Initial	2	IV-E	Operating Under Freezing Conditions	10
I-D	Piping—General	3	SECTION V — TROUBLE CHECK LIST		
I-E	Piping—Suction	3	V-A	No Water Delivered	11
I-F	Piping—Discharge	4	V-B	Not Enough Water Delivered .	11
I-G	Connection of Piping	4	V-C	Not Enough Pressure	11
I-H	Check of Rotation	4	V-D	Pump Works Awhile and Then Quits	11
I-J	Connection of Coupling	5	V-E	Pump Takes Too Much Power	11
SECTION II — PREPARATION FOR OPERATION			V-F	Pump Leaks Excessively at Stuffing Box	11
II-A	Pump Bearings	5	V-G	Pump is Noisy	11
II-B	Driver Bearings	5	SECTION VI — CARE AND MAINTENANCE		
II-C	Stuffing Boxes	5	VI-A	Lubrication of Pump Bearings	12
II-D	Connection of Equalizing Piping	6	VI-B	Lubrication—Driver & Cplg. . .	12
II-E	Connection of Piping to Quenching Gland	6	VI-C	Sectional Assembly and Inter- changeability Chart	14 & 15
II-F	Connection of Cooling Water Piping	6	VI-D	Repacking Stuffing Boxes	12
II-G	Connection of Drain Piping . .	7	VI-E	Dismantling of Pump	12
SECTION III — STARTING PUMP			VI-F	Overhaul of Pump	17
III-A	Priming	7	VI-G	Reassembly of Pump	18
III-B	Regulation of Water Cooling Flow	9	VI-H	Changing Rotation of Pump in Field	21
III-C	Adjustment of Stuffing Box Gland	9	VI-I	Emergency Ball Bearing Replacement	21
III-D	Alignment—Final	9	VI-J	Spare Parts	21
III-E	Doweling	9	VI-K	Instructions for Ordering Repair Parts	22
SECTION IV — OPERATION					
IV-A	Stuffing Box (Including Mechanical Seal)	10			
IV-B	Operating at Reduced Capacities	10			

Section I - Installation

I—A. LOCATION.

Pumping unit should be placed as close as practical to the source of supply. Always allow sufficient head room to remove the upper half casing of the pump and the rotating element. Floor space allotted to the pumping unit should be sufficient for inspection and maintenance.

I—B. FOUNDATION.

1. The foundation should be substantial in order to absorb any vibration and to form a permanent rigid support for the bedplate. A concrete foundation poured on a solid footing, using a one-three-five mix, of a liberal thickness to support the pumping unit is satisfactory.

2. Foundation Bolts:

(a) The location and size of the foundation bolts is shown on the outline assembly drawing supplied for the pumping unit.

(b) Each bolt should be installed with a pipe sleeve around it — to allow for adjustment. The inside sleeve diameter should be $2\frac{1}{2}$ to 3 times the diameter of the bolt. Place a washer between bolt head and sleeve to hold bolt in position. Stuff waste around foundation bolts to prevent concrete from entering between the bolt and pipe sleeve. See Fig. 1.

(c) The foundation bolts should be of sufficient length so that they project through the nut approximately $\frac{1}{4}$ " after allowance has been made for grouting ($\frac{3}{4}$ " to $1\frac{1}{2}$ "), the thickness of the bedplate, and the thickness of the foundation bolt nut. See Fig. 1.

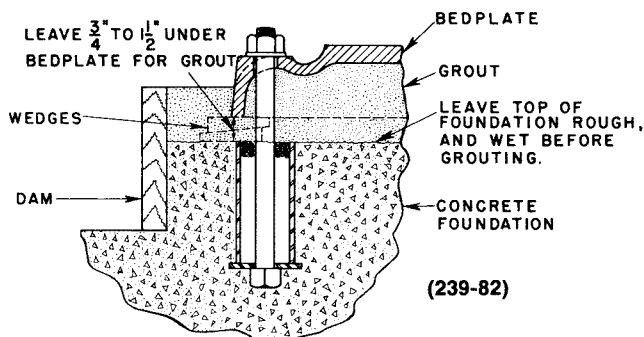

Figure 1

3. Preparing Foundation for Mounting:
Prior to setting unit upon the foundation, clean the top surface of concrete.
4. Mounting Unit on Foundation:
(a) Put the pumping unit in place on the wedges. The wedges should be placed at four points, two below the approximate center of the pump and two below the approximate center

of the driver (See Fig. 2). Some installations may require additional wedges near the middle of the bedplate.

(b) Be sure that coupling is disconnected between pump and driver.

(c) By adjustment of the wedges, bring the unit to an approximate level and provide for the proper distance above the foundation for grouting ($\frac{3}{4}$ " to $1\frac{1}{2}$ "). Plumb the suction and discharge flanges. By further adjustment of the wedges, bring the coupling halves into reasonable alignment. Check by method described in Section I—C 4-6.

(d) After the wedges have been adjusted, tighten foundation bolts evenly but only finger tight.

NOTE: Final tightening of foundation bolts is done after grout has set 48 hours.

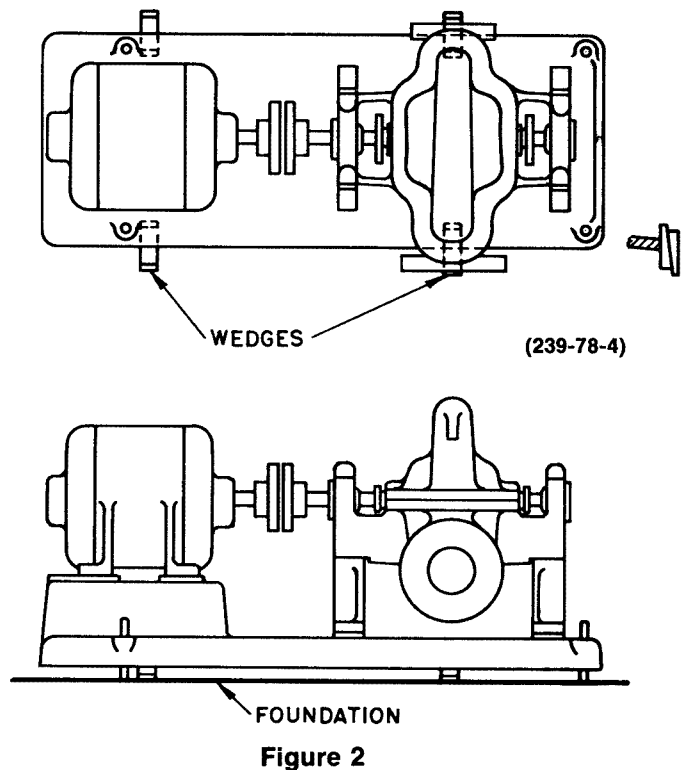

5. Grouting Unit on Foundation:
(a) Build wood dam around foundation as shown in Fig. 1. Wet top surface of concrete foundation thoroughly.
(b) Pour grout in hole provided in the top of the bedplate. Use of a non-shrink grout is recommended. The grout should be thin enough to flow out under the bedplate. A mixture of one part Portland cement to three parts sharp sand may also be used. Cement grout should not be so thin that the cement will separate from the sand.

(c) The grout should be puddled continuously as it is poured to expel the air and completely fill the space under the bedplate, to the level of the grout hole in the top of the bedplate.

(d) With a trowel, strike along the top of the wood dam to give a neat, finished appearance at this point.

(e) Allow grout to harden at least 48 hours.

I—C. ALIGNMENT — INITIAL.

Alignment of the pump and driver through the flexible coupling is of extreme importance for trouble-free mechanical operation.

If the driver was mounted at the factory, the unit was in alignment before it left our assembly department. However, in transit and subsequent handling, this factory alignment was probably destroyed; and, it is now necessary to reestablish the alignment. As directed in Section I—B 4 (c) only *approximate* alignment was obtained by wedging under bedplate before grouting.

The following are suggested steps to establish the initial alignment of the pumping unit.

(NOTE THAT THIS IS AN INITIAL ALIGNMENT. THE FINAL ALIGNMENT IS DONE AFTER THE UNIT HAS BEEN RUN UNDER ACTUAL OPERATING CONDITIONS. THE FINAL ALIGNMENT PROCEDURE IS OUTLINED IN SECTION III-D AND MUST BE FOLLOWED.)

1. Be sure coupling halves are disconnected.
2. Tighten foundation bolts.
3. Tighten pump and driver hold-down bolts.
4. Any coupling manufacturer's instruction sheets sent with the pump should be studied and used when installing, aligning, or servicing coupling. Align coupling, following manufacturer's instructions. If instructions are not available, the following procedure (steps 5 and 6) may be used.
5. Check angular misalignment — shaft axes concentric but not parallel — by inserting a taper gauge or feeler at four points on the circumference of coupling halves at 90° intervals. See Fig. 3. The unit will be in angular alignment when the measurements show the coupling faces are the same distance apart at all points. The "gap" between the coupling halves should be checked at this time. This depends on the type of coupling used and this information will be found in the instructions for the specific make of coupling furnished. Adjust angular alignment and "gap" by loosening the driver hold-down bolts and shifting or shimming driver as required. Tighten driver hold-down bolts after angular alignment and correct "gap" are secured.

NOTE — Pumps and drivers are bed-plated so that when coupling faces are positioned in accordance with the manufacturer's recommended gap, there is an overhang of approximately $\frac{1}{8}$ " from shaft ends to coupling hub faces.

6. Check parallel misalignment — shaft axes

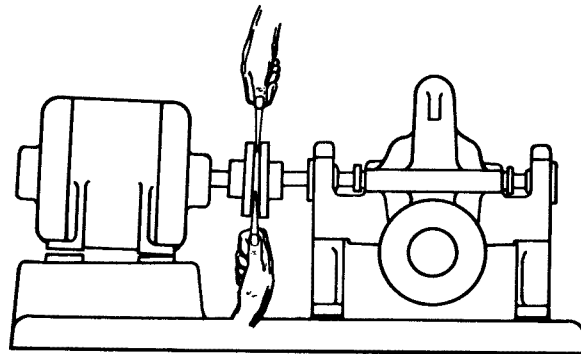
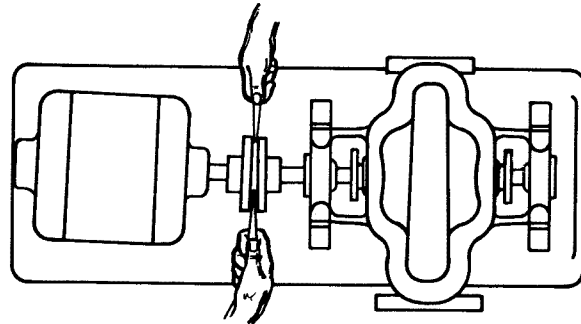

Figure 3

(239-81-6)

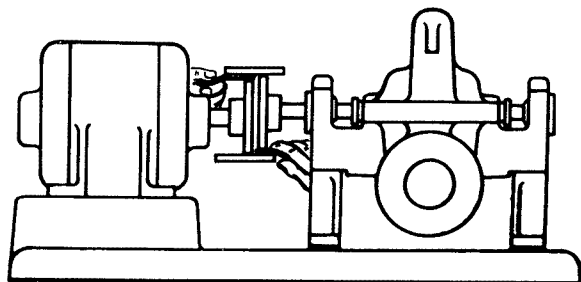
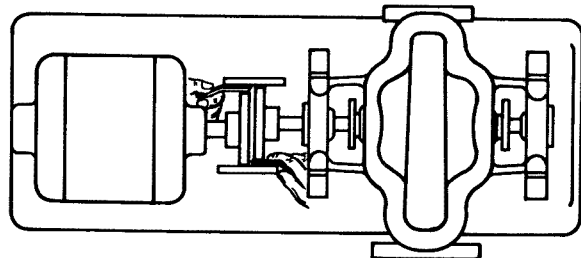

Figure 4

(239-81-7)

parallel but not concentric—by laying straight edge across both coupling rims at top, bot-

tom and both sides. See Fig. 4.

The unit will be in horizontal parallel alignment when the straight edge rests evenly on both halves of the coupling at each side.

In order to secure vertical parallel alignment under actual operating conditions, the driver shaft must be set 0.002-0.004" lower than the pump shaft to compensate for vertical expansion.

Thin shim stock should be used under the driver feet to establish parallel alignment. (In some instances, shims may be required under the pump feet.)

7. Bear in mind always that alignment in one direction may alter the alignment in another. Check through each alignment procedure after making any alignment alteration.

I—D. PIPING — GENERAL.

1. All piping must be supported independently of the pump. The piping should always "line-up" naturally with the pump flanges. NEVER DRAW THE PIPING INTO PLACE BY USE OF FORCE AT THE FLANGED SUCTION AND DISCHARGE CONNECTIONS OF THE PUMP!
2. The piping, both suction and discharge, should be as short and direct as possible. Avoid all unnecessary elbows, bends and fittings, as they increase the friction losses in the piping. The size of pipe and fittings should be carefully selected and of sufficient size to keep the friction losses as low as practical.
3. Piping must not be connected to the pump until the grout has thoroughly hardened and the foundation bolts as well as driver and pump hold-down bolts have been tightened. See Section I—G.
4. When handling liquids at elevated temperatures, arrangements must be made for expansion loops or expansion joints so that the linear expansion of the pipe will not cause the pumping unit to be drawn out of alignment.

I—E. PIPING — SUCTION.

1. General — Properly installed suction piping is of extreme importance for trouble-free centrifugal pump operation.
 - (a) The suction pipe should be as large or larger than the pump suction.
 - (b) Increases, if used, should be eccentric and preferably at the pump suction flange, sloping side down.
 - (c) A centrifugal pump should *never* be throttled on the suction side for capacity adjustment.

(d) When more than one pump is operating from the same source of supply, separate suction lines, if possible, should be used. If not possible for separate lines, piping arrangement as shown in Fig. 7 is recommended.

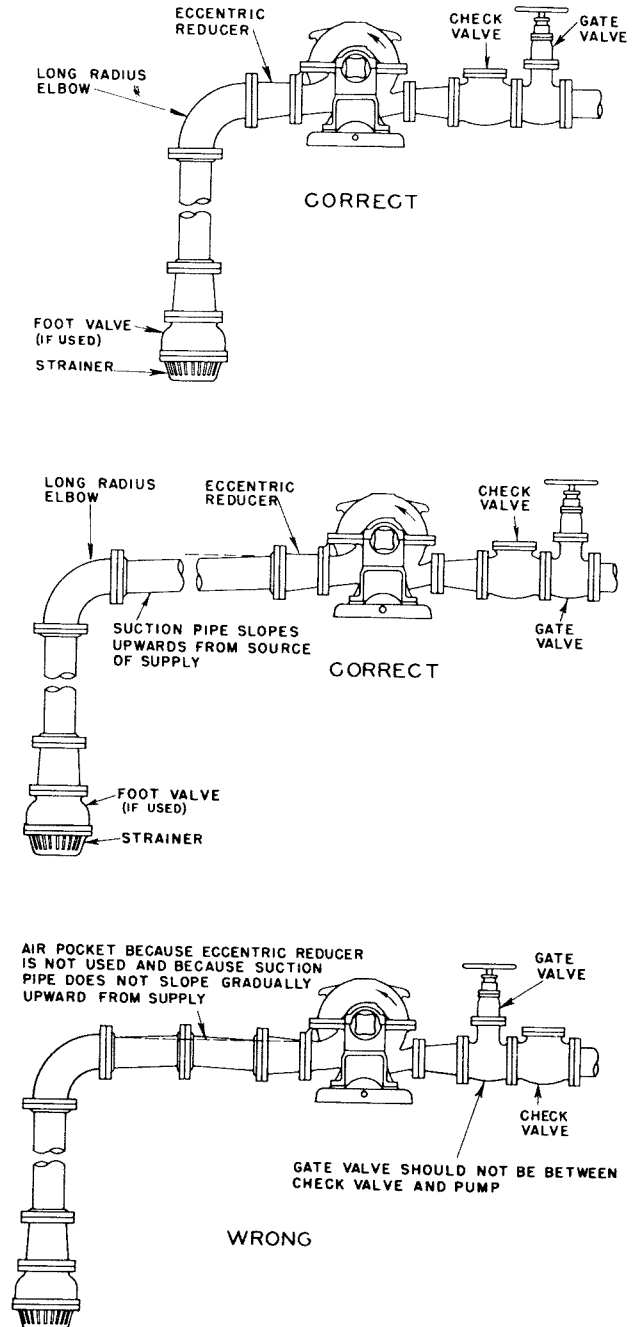

Figure 5

(239-81-1)

2. Installations With Pump Above Source of Supply — Suction Lift:
 - (a) Keep suction pipe free from air pockets. See Fig. 5.
 1. Piping should slope upwards from source of supply.
 2. No portion of piping should extend above

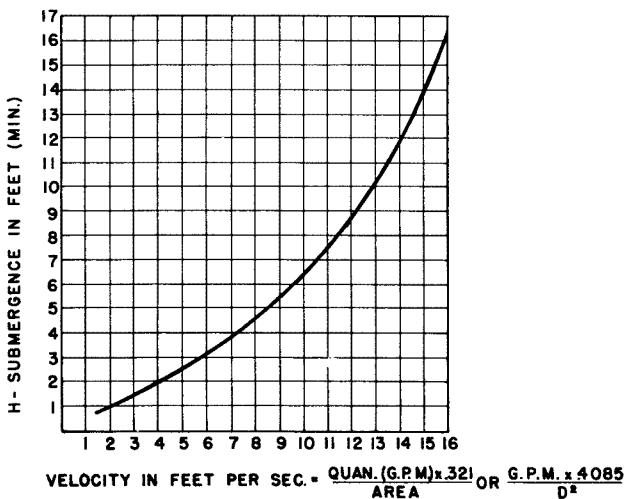
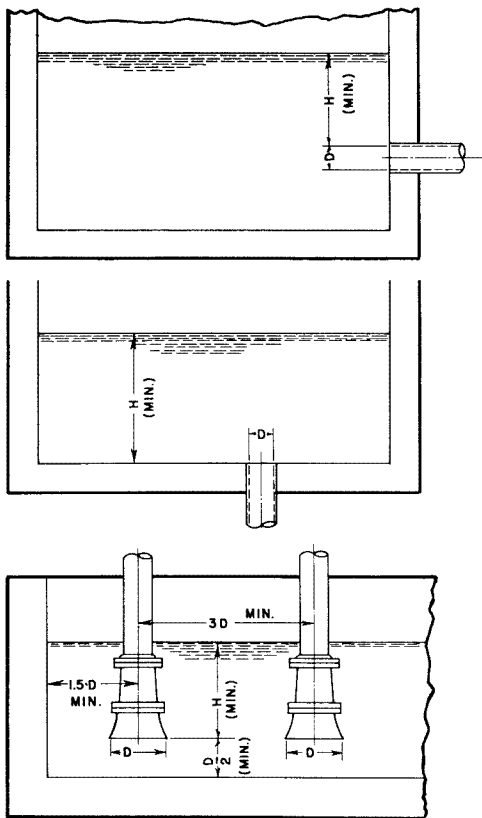

Figure 6

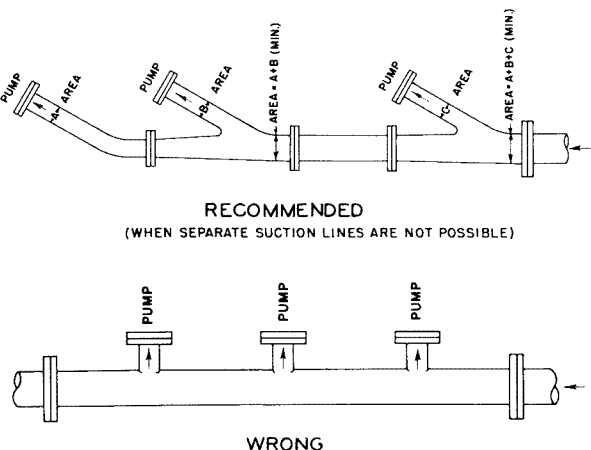

Figure 7

(239-95-1)

the pump suction nozzle.

(b) All joints must be air tight.

(c) The suction pipe should always be submerged into the source of supply as shown in Fig. 6.

(d) A foot valve should only be used if necessary for priming, or, if the pump is to be used on intermittent service and is required to hold its prime.

(e) Suction strainers when used should have a net free area of at least three times the suction pipe area.

3. Installations With Pump Below Source of Supply — Suction Head or Flooded Suction:

(a) A gate valve should be installed in the suction line to permit closing the line for pump inspection and maintenance.

(b) Keep suction pipe free from air pockets.

1. Piping should be level or slope gradually downward from the source of supply.

2. No portion of the piping should extend below the pump suction flange.

(c) The size of entrance from the supply should be no smaller than the suction pipe.

(d) The suction pipe should be below the liquid surface at the source of supply as shown in Fig. 6.

I—F. PIPING — DISCHARGE.

1. A gate valve and a check valve should be installed in the discharge line. The check valve should be located between the gate valve and pump to permit inspection of the check valve. The gate valve is required for priming, regulation of flow capacity and for inspection and maintenance of the pump. See Fig. 5.

2. Increases, if used in discharge line, should be placed between the check valve and the pump.

I—G. CONNECTION OF PIPING.

Connect suction and discharge piping. Rotate the pump shaft by hand several complete revolutions to be sure that there is no binding and that all parts are free. Recheck alignment as described in Section I—C. If the connection of the piping causes unit to be out of alignment, correct piping to relieve strain on the pump.

I—H. CHECK ROTATION.

The direction of rotation is marked on the pump casing. Make sure that driver rotates in the same direction. On electric motors, jog starting switch to be sure wiring is connected for correct rotation. Be sure that coupling is

disconnected.

I—J. CONNECTION OF COUPLING.

Connect coupling, following instructions for the particular make of coupling furnished. This data is supplied separately, giving complete instructions for connection, lubrication, alignment and maintenance.

Section II Preparation for Operation

II—A. PUMP BEARINGS.

The pump bearings are flood oil lubricated, and are not lubricated at the factory.

A high quality turbine type oil, with rust and oxidation inhibitors, should be used. For the great majority of operating conditions, oil temperature will run between 50 and 180° F. In this range an oil of 300 SSU viscosity at 100° F. (approximately SAE 20) should be used. If oil temperature exceeds 180° F. for extended periods, use of cooling water as outlined in Section II—F and/or use of a special high temperature oil should be considered. For extreme conditions, refer to factory or a lubrication expert for a recommendation.

The constant level oilers are in the box of fittings which accompany the pump. Oiler manufacturer's instructions accompany the oiler. Oiler was adjusted to maintain proper oil level before leaving factory. If adjustment is lost, reset as illustrated below. Install the constant level oilers in the bearing end cover at each end of the pump. Do not install the oiler in the openings for the optional cooling coils, which are directly below the oiler. See Sectional Assembly, Section IV—C.

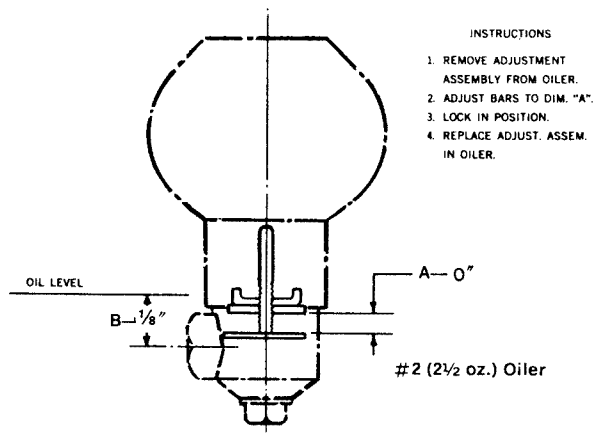

Fill the oiler bottle with oil, and replace in the oiler. The housing is filled when an oil level remains in the oiler bottle. More than one filling of the bottle may be required. Never fill the housing through the oiler without use of the

NOTE — Pumps and drivers are bedplated so that when coupling faces are positioned in accordance with the manufacturer's recommended gap, there is an overhang of approximately 1/8" from shaft ends to coupling hub faces.

bottle.

II—B. DRIVER BEARINGS & COUPLING.

Check to be sure the driver bearings and coupling are properly lubricated.

II—C. STUFFING BOXES

Pumps are furnished with packing rings as standard. However, mechanical seals, either single or double, can be furnished on order.

1. Stuffing Boxes with Packing Rings:

(a) The stuffing box packing is in the box of fittings accompanying the pump. The standard packing is John Crane "Super Seal" No. 1. "Super Seal" No. 1 is recommended for water, ammonia, mild chemicals and all general services, and is good for the maximum temperatures for which the pumps are rated. Packing is die formed for easy installation.

(b) When installing the packing and the Teflon lantern ring, twist the rings sideways just enough to get them around the shaft sleeves.

DO NOT ATTEMPT TO PULL RINGS STRAIGHT OUT TO GET THEM OVER SHAFT AND SHAFT SLEEVE. See Fig. 8.

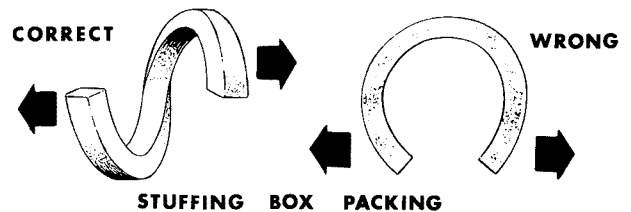
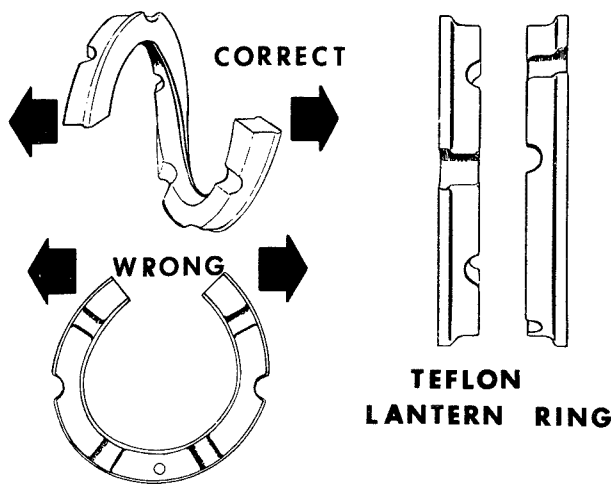

Figure 8

(c) Insert lantern ring (105) against stuffing box bushing (125) (2 pieces make one ring). NOTE: Notches must face one another but need not be aligned.

(d) Then insert five rings of packing for Group "S" and "M" pumps and six rings for



Group "L" pumps, staggering the joints. See sectional assembly, Section VI—C. Each ring should be firmly seated before the next ring is added. Two extra rings of packing are furnished in each set of packing. The extra ring for each side may be added as required.

(e) Insert gland packing (210) into recess in each gland half and trim off excess flush with face of each gland half.

(f) Run ½"—13 UNC nuts (355) about three-fourths the length of the threaded part of bolts (353) and place cupped washers (354) on gland bolts. (See Fig. 9).

(g) Insert lower half gland (107) into stuffing box.

(h) Insert round, flattened end of gland bolts into recess of bearing housing (134 or 166). Gland bolts do *not* screw into tapped holes in casing. Tapped holes in casing are for mechanical seal gland only when pumps are furnished with seals. Threaded portion of gland bolt lays on gland half.

(i) Insert upper half gland into stuffing box. Place cupped washers over the bosses on the gland to hold the gland halves together.

(j) Draw the gland nuts up evenly but not tight.

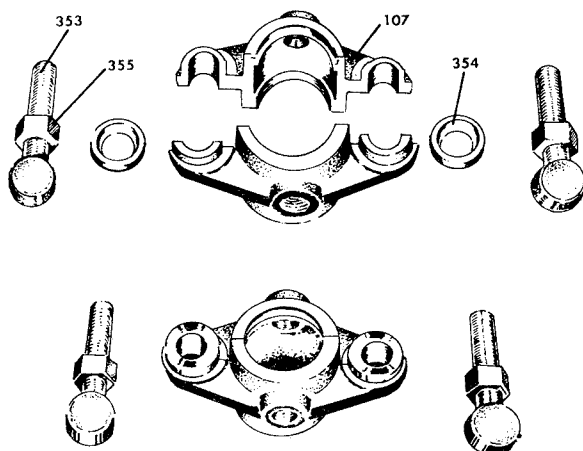

Figure 9

2. Stuffing Boxes with Mechanical Seals:

When mechanical seals are furnished the description and identification is indicated on the order write ups which are part of the order acknowledgment, certified dimension print and the packing list. Separate installation drawings which include startup and operating instructions will be found with the instruction book attached to the pump.

The seal was installed at the factory and no further adjustment is required.

Specific instructions for preparation for operation, however, must be adhered to. Note particularly the instructions pertaining to flushing, quenching, cooling and/or pressurizing. Failure to follow instructions may cause seal damage. Consult factory or seal representative if necessary.

II—D. CONNECTION OF EQUALIZING PIPING.

The equalizing pipe (102) and fittings are shipped separately in the box of fittings accompanying the pump. The ends of the piping must be connected to the openings in the top of each stuffing box for equalizing the pressure on the two boxes. See Section VI—C (page 12). This piping must be used on all units, including pumps fitted with single or double mechanical seals.

II—E. CONNECTION OF PIPING TO QUENCHING GLAND.

The stuffing box gland can be operated with or without quenching water. Quenching is recommended on applications where the liquid pumped is

- 1) Hot water above 212° F
- 2) Between 250° and 350° F in addition to bearing housing cooling.
- 3) Volatile or toxic, in order to smother the gland leakage, which then can be piped away.

The quenching liquid must be from an outside source and should be piped with a flexible pipe, into the opening in the upper gland half and allowed to drain into chamber or pocket in lower half casing. The openings in the gland halves are tapped for ¼" pipe. A shut-off valve should be installed in each quenching line.

II—F. INSTALLATION AND CONNECTION OF BEARING COOLING WATER PIPING.

Bearing cooling coils are supplied when ordered. Bearings should be cooled when the liquid pumped is:

1. Between 250° and 350° F, in addition to gland quenching.

The cooling coils are installed as follows:

1. Refer to Section VI—C which shows the installed cooling coil.
2. Special fittings and tubing are in the box of fittings sent with the pump.
3. Remove four — ¼" plugs from bearing end covers (109 and 119) — one plug from each side of each cover. The plugged openings are those below the openings for the constant level oilers.
4. Screw ¼" pipe x ¼" OD tube compression fittings into each of the four openings.
5. Push each ¼" OD x 9 " long copper tube through one fitting until it comes out the

fitting on the other side. Center tubing so that equal lengths project from each side. Tighten nuts on compression fittings.

6. Connect the ¼" pipe x ¼" OD tubing elbow to each end of the copper tube. This provides a ¼" pipe connection for cooling water piping.
7. Connect cooling water. The inlet line should have a shutoff valve to regulate flow.

II—G. CONNECTION OF DRAIN PIPING.

Connect overflow outlets from stuffing boxes (located in casing near pump feet) to drain, and connect overflow from bedplate (located at pump end of bedplate) to drain. All of the above overflow openings are tapped for ¾" pipe.

Section III – Starting Pump

III—A. PRIMING.

The pump must always be fully primed and the suction pipe full of liquid before pump is started.

If pump is run dry, the rotating parts within the pump may seize to the stationary parts as they depend on the liquid being pumped for lubrication.

Several different methods of priming can be used, depending on the type of installation and service involved.

Note: If the pump is being used to pump potable or drinking water, the priming line should be protected against back-siphonage by the installation of a check valve and an approved type vacuum breaker.

1. Suction Supply Above Pump:

When pump is installed as shown in Fig. 10, pump will prime itself. Open gate valve on suction and close discharge gate valve. *Open air vent valves until all air is expelled and water flows through openings.* Close air vent valves, start pump, open discharge gate valve, and pump will continue to be primed for any future starting.

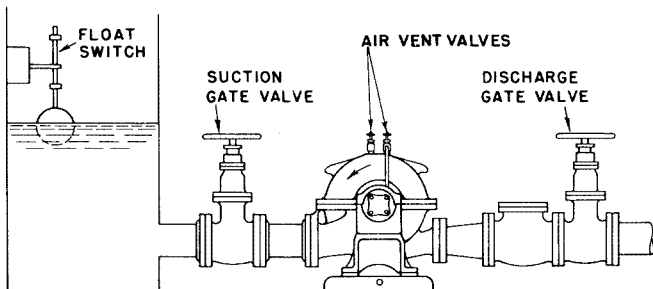

Figure 10

240-56-1

This method is the simplest and, particularly for automatic operation, the safest. A float switch in the suction reservoir can be arranged to stop pump, should there be failure of liquid supply.

2. Priming With Foot Valve:

With pump installed on suction lift, and with foot valve at end of suction line, priming can be done any of the following three ways:

(a) *From Some Outside Supply* (See Fig. 11).

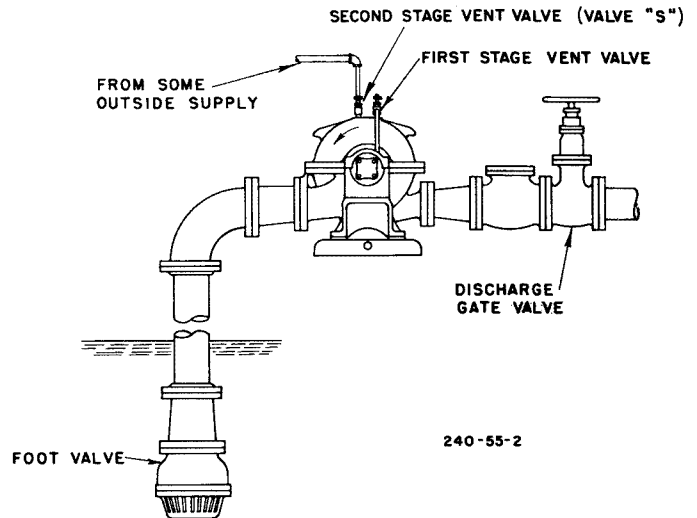

Figure 11

(240-55-2)

Close discharge gate valve, open 1st stage vent valve and open valve "S" in priming supply line until all air is expelled and water issues from vent opening. Close valve "S", close 1st stage air vent valve and start pump; then open discharge gate valve.

(b) *By Separate Hand or Manually Controlled Priming Pump* (See Fig. 12).

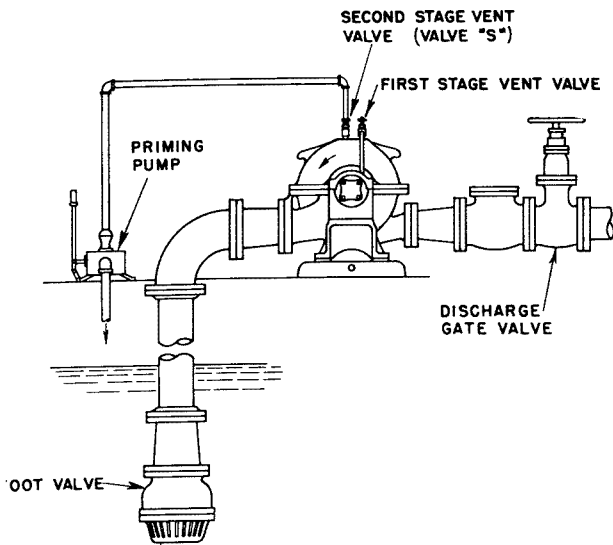

Figure 12 240-55-3

Close discharge gate valve (keep 1st stage air vent valves closed) and open 2nd stage air vent valve (valve "S") in line to priming pump. Exhaust air from pump and suction piping until water flows from priming pump. Close valve "S", start pump and open discharge gate valve.

By reversing connections on priming pump and extending priming pump suction to source of liquid supply, centrifugal pump may be primed by pumping liquid into casing until liquid comes out of the open 1st stage air vent valve.

In either of these methods (a) and (b), the pump will remain primed, provided foot valve is tight. Any failure, however, of foot valve when pump is standing idle, will permit the pump to lose its prime. During long idle periods, the pump can also lose its prime through leakage from stuffing boxes.

(c) *Bypassing Around Discharge Check Valve* (See Fig. 13).

This method can be used only when there is liquid under some pressure in the discharge line. The original prime must be effected from some outside source. After subsequent idle periods, open air vent valves and open valve in bypass line around discharge check and gate valves until liquid flows from air vent openings. Close air vent valves and bypass valve, start pump and open discharge gate valve.

The valve in bypass can be left open, in which event, during idle periods, loss through foot valve is constantly replenished from discharge line. This system is used for automatic operation where idle periods are of short duration and there is no danger of exhausting all liquid from discharge line, due to a leaky foot valve. If the valve in the bypass is left open, as described above, the

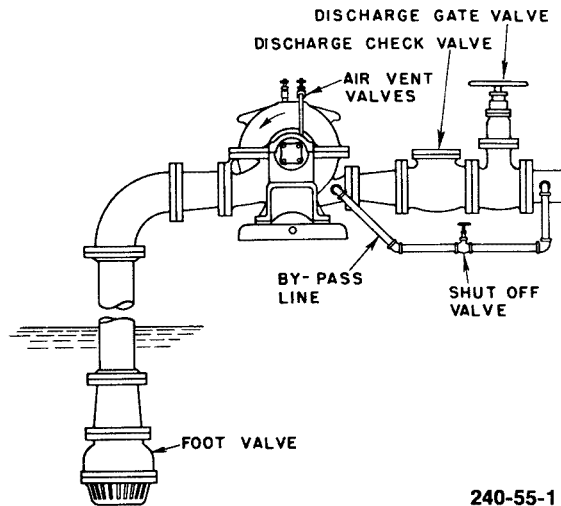

Figure 13

240-55-1

foot valve must be capable of withstanding static head pressure of the system.

3. Priming by Ejector (See Fig. 14):

On suction lift installations, an ejector, operated by steam, compressed air, or water under pressure, and connected to tapped opening in second stage vent valve (remove vent tubing and fitting from valve) can be used to remove air from casing and suction line, thus priming the pump.

Close discharge gate valve, open valve "E" in steam, air or water pressure supply line. Open valve "S" in suction pipe of ejector connected to pump casing. Air will be evacuated and liquid will be drawn up into suction pipe and pump casing. When all air is evacuated, start pump, close valve "S" and valve "E", and open discharge gate valve.

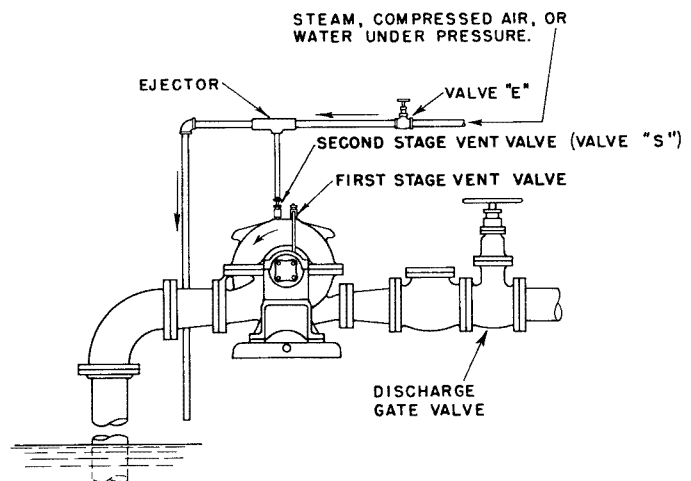

Figure 14

240-56-2

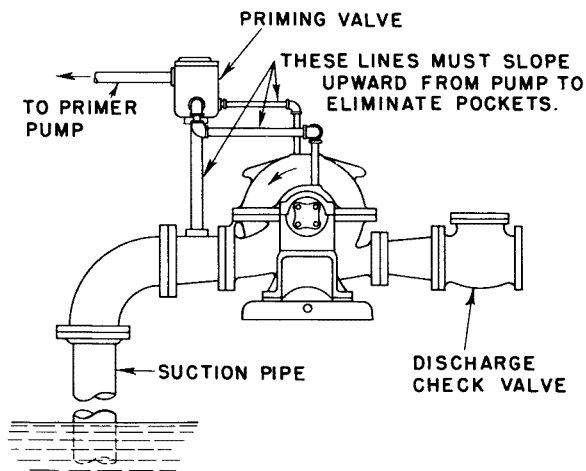

Figure 15 (239-77-2)

4. Priming by Automatic Primer Pump (See Fig. 15):

Where there is a fluctuating suction lift that occasionally might drop below the normal limits of the pump or for installations where there is any quantity of air entrained with the liquid being pumped, the system shown in Fig. 15 is very well adapted.

A vacuum tank and a vacuum gauge can be installed near the primer pump and the vacuum switch set to automatically start or stop the primer pump according to the vacuum required to keep the system primed.

III—B. REGULATION OF COOLING WATER FLOW.

The supply of liquid to the water-cooled bearings and quenching glands should be regulated by valves in the supply line. Approximately $\frac{1}{2}$ G.P.M. to each gland and 1 G.P.M. to each bearing cooling coil is sufficient. The cooling lines should be checked periodically to see that they have not become clogged.

III—C. ADJUSTMENT OF STUFFING BOX GLAND.

With pump running at rated speed, stuffing box glands can be adjusted. Draw gland nuts up evenly and only one-sixth of a turn at a time, allowing sufficient time between adjustments for the packing to adjust itself and the effect on the leakage to be observed. If any sign of heating is evident, shut off the pump and allow the boxes to cool. Several starts may be necessary before the boxes run cool. Do not back off the gland nuts on a hot box as this will usually result in liquid leaking between the outer edge of the packing and the stuffing box bore. It must be borne in mind that it takes newly-installed packing

some time to "run in" and that during this period, frequent attention and careful adjustments are necessary. See IV—A for final adjustments of gland.

III—D. ALIGNMENT — FINAL.

Final alignment can only be accomplished after unit has been run under actual operating conditions for a sufficient length of time to bring the unit up to operating temperatures.

After this warm-up period has elapsed, stop the unit and immediately disconnect the coupling and check the alignment.

Follow the alignment procedure as outlined in I—C, with the exception of Paragraph I—C 6 which allows for "growth" of the parts due to temperature difference between the driver and the pump. At the operating temperature, the unit will be in correct horizontal and vertical parallel alignment when a straight edge rests evenly on both halves of coupling rims at four points 90° apart.

As cautioned in I—C 7, changing alignment in one direction may alter the alignment in another. Check thru each alignment procedure after making any alignment change.

III—E. DOWELING.

Doweling is not required on Group "S" and "M" pumps. On these pumps, patented lock washers are furnished which hold the pump and driver feet securely in place.

On Group "L" pumps, the pump and driver should be doweled after installation is complete and the unit is in correct final alignment. Four #6 taper dowel pins are included in the box of fittings accompanying the pump. These pins have a taper of $\frac{1}{4}$ " to the foot. The diameter at large end is .341" (approximately $\frac{1}{32}$ ") and the recommended drill size is $\frac{9}{32}$ ".

Drill through two diagonally opposite feet of the pump and driver into the bedplate. Use a reamer with a taper of $\frac{1}{4}$ " to the foot. Ream out the drilled holes so that dowels extend well into the bedplate but project above the pump and driver feet.

If the operator so desires, the same size pins and method of doweling can be used on Series "S" and "M" pumps in addition to the patented lock washers.

To determine the group of a particular size pump, see interchangeability list, Section VI—C.

Section IV – Operation

IV—A. STUFFING BOX.

1. Stuffing Boxes with Packing Rings — Less Quenching Gland:

Periodically inspect stuffing box to see that there is sufficient leakage to lubricate the packing and maintain a cool box. Never draw up packing so that the stuffing box heats, as this will cause damage to both packing and sleeve. Always draw up gland nuts evenly and when pump is running.

After pump has been in operation for some time and the packing has been completely run in, at least 40 to 60 drops per minute of the liquid should be allowed to trickle from the stuffing box at all times for cooling and lubricating the packing and shaft sleeve.

2. Stuffing Boxes With Packing Rings — With Quenching Gland:

The same precautions as described above apply. However, the amount of leakage through the packing cannot be so readily ascertained, due to the quenching liquid. In most cases, the valve on the quenching liquid supply line can be shut off for a short period and the amount of leakage determined as in IV—A 1. In no instance should the gland be drawn up tight.

3. Stuffing Boxes with Mechanical Seal:

This type of box requires no attention other than to make sure that the circulating lines do not become clogged.

IV—B. OPERATING AT REDUCED CAPACITIES.

Do not operate a centrifugal pump at greatly reduced capacities or with discharge gate valve closed, because the energy required to drive the pump is converted into heat. If this condition exists over a long period, the temperature of the liquid in the pump may increase until the boiling point is reached. If this occurs, the rotating parts are exposed to vapor with no lubrication and they may score or even seize to the stationary parts; and furthermore, if running clearances have enlarged due to wear, seizure may not take place. Continued operation under these conditions may create an explosive hazard due to the confined vapor under high pressure and temperature.

To guard against possible damage, protective devices are available, such as:

1. Liquid temperature relay or thermostat which will shut-off the unit if the liquid temperature in the pump exceeds a predetermined maximum. This device guards against possible damage due to running the pump against a closed

valve.

2. Constant open by-pass orifice between the pump discharge and any check or regulating valve in the discharge line. The liquid through the orifice is returned to the suction source. The amount of liquid by-passed is a function of input horsepower and the allowable temperature rise. This device also is insurance against damage due to running the pump against a closed discharge valve or very low flow conditions.

3. Bearing temperature relay which will shut the unit down if the bearing temperature exceeds a predetermined maximum.

4. Low suction pressure control which will shut off the unit should the suction pressure drop below a pre-established minimum.

A centrifugal pump should *never* be throttled for capacity adjustment on the suction side.

IV—C. OPERATING AT REDUCED HEAD.

On motor driven pumps, when discharge head or pressure is allowed to drop considerably below the rated point for any length of time, the motor should be watched for heating because the pump capacity increases rapidly with reduced head, as does horsepower consumption. If this condition is likely to persist, arrangements should be made either to manually or automatically throttle the discharge valve to build up head to a safe point.

IV—D. OPERATING WITH SURGE CONDITIONS IN LINE

If pump is installed with a quick closing valve in discharge line that closes when pump is running, dangerous pressure surges may be built up that can cause damage to the pump or line. In services of this kind, some cushioning arrangement must be provided to protect the pumping equipment.

IV—E. OPERATING UNDER FREEZING CONDITIONS.

When exposed to freezing conditions and pump is standing idle, liquid inside the pump should be drained by removing drain plugs in bottom of casing and opening air cocks at top. Cooling water should also be drained from the water-cooled bearing (if water-cooled bearings are used).

Section V Trouble Check List

V—A. NO WATER DELIVERED.

1. Priming — casing and suction pipe not completely filled with liquid.
- *2. Speed too low.
3. Discharge head too high. Check total head (particularly friction loss).
4. Suction lift too high (suction pipe may be too small or long, causing excessive friction loss). Check with gauge.
5. Impellers or suction pipe or opening completely plugged.
6. Wrong direction of rotation.
7. Air pocket in suction line.
8. Stuffing box packing worn — allowing leakage of air into pump casing.
9. Air leak in suction line.
10. Not enough suction head for hot water or volatile liquids. Check carefully as this is a frequent cause of trouble on such service.

V—B. NOT ENOUGH WATER DELIVERED.

1. Priming — casing and suction pipe not completely filled with liquid.
- *2. Speed too low.
3. Discharge head higher than anticipated. Check total head (particularly friction loss).
4. Suction lift too high (suction pipe may be too small or long, causing excessive friction loss). Check with gauge.
5. Impellers or suction pipe or opening partially plugged.
6. Wrong direction of rotation.
7. Air pocket in suction line.
8. Stuffing box packing worn — allowing leakage of air into pump casing.
9. Air leak in suction line.
10. Not enough suction head for hot water or volatile liquids. Check carefully as this is a frequent cause of trouble on such service.
11. Foot valve too small.
12. Foot valve not immersed deeply enough.
13. Mechanical defects:
 - Wearing rings worn.
 - Impellers damaged.
 - Casing gasket defective.

* When connected to electric motors, check whether motor wiring is correct and receives full voltage. When connected to steam turbines, make sure that turbine receives full steam pressure.

V—C. NOT ENOUGH PRESSURE.

- *1. Speed too low.
2. Air in water.
3. Impeller diameters may be too small.

4. Mechanical defects:
 - Wearing rings worn.
 - Impellers damaged.
 - Casing gasket defective.
5. Wrong direction of rotation.
6. Be sure pressure gauge is in correct place on discharge nozzle of pump and not on top of casing.

V—D. PUMP WORKS AWHILE AND THEN QUILTS.

1. Leaky suction line.
2. Stuffing box packing worn — allowing leakage of air into pump casing.
3. Air pocket in suction line.
4. Not enough suction head for hot water or volatile liquids. Check carefully as this is a frequent cause of trouble on such service.
5. Air or gases in liquid.
6. Suction lift too high (suction pipe may be too small or long, causing excessive friction loss). Check with gauge.
7. Impellers plugged.

V—E. PUMP TAKES TOO MUCH POWER.

- *1. Speed too high.
2. Head lower than rating, pumps too much water.
3. Liquid heavier than water. Check viscosity and specific gravity.
4. Mechanical defects:
 - Shaft bent.
 - Rotating element binds.
 - Stuffing box too tight.
 - Pump and driving unit misaligned.
- *5. Wrong direction of rotation.

V—F. PUMP LEAKS EXCESSIVELY AT STUFFING BOX.

1. Packing is worn or not properly lubricated.
2. Packing is incorrectly inserted or not properly run in.
3. Packing is not right kind for liquid handled.
4. Sleeves scored.

V—G. PUMP IS NOISY.

1. Hydraulic noise — cavitation, suction lift too high. Check with gauge.
2. Mechanical defects:
 - Shaft bent.
 - Rotating parts bind, are loose or broken.
 - Bearings worn out.
 - Pump and driving unit misaligned.

Section VI Care and Maintenance

VI—A. LUBRICATION — BEARINGS.

1. Keep oiler bottle filled with correct grade of oil. (See Section II—A). Oiler will maintain constant oil level in bearing housing.
2. Under normal operating conditions, a good grade of oil will be suitable for 6 months to one year between changes, as long as it is free from contaminants. A small sample of oil should be drained from the bearing housing periodically. Any cloudiness, turbidity, discoloration or presence of solids is evidence of contamination, and the oil should be changed immediately.
3. If oiler adjustment is lost or disturbed, reset as directed in Section II—A.
4. Bearing Temperatures — All bearings operate at some temperature above that of the surrounding atmosphere, unless cooled. Heat is generated within the bearing due to rolling friction, and the drag of the race. Do not use the human hand as a thermometer. A temperature which feels "hot" varies from 120° to 130° F. depending on the individual. Above this temperature the human hand is worthless in estimating temperature. Oil lubricated ball bearings can be operated safely at temperatures up to at least 180° F. Bearing temperatures up to 160° F. are normal. Determine the temperature accurately by placing a contact type thermometer against the bearing housing. This temperature should be recorded in a convenient location. A stable temperature is an indication of normal operation.

A sudden increase in temperature is an indication of danger and a signal to investigate. Check to see that oil is of proper viscosity and that oil level is neither too high nor too low. The unit should also be checked for unstable hydraulic operation and unnecessary loads, such as coupling misalignment.

Occasionally, when the pumps are first started, the bearings seem to run extremely hot. This high temperature is frequently caused by oil seals, not the bearings. As soon as the seals are seated, the temperature will drop to a normal level.

VI—B. LUBRICATION — DRIVER AND COUPLING.

Follow manufacturer's recommendations.

VI—C. SECTIONAL VIEW (See p. 14, 15)

VI—D. REPACKING STUFFING BOXES.

1. To remove stuffing box gland assembly: Back off nuts (355). Slip the cupped washers (354) from bosses on gland, lift the upper gland half out of stuffing box and remove the gland bolts and lower gland half. This now affords unobstructed access to the stuffing box for repacking.
2. Remove the rings of packing with the aid of a packing hook.
3. Remove split lantern ring by inserting a wire hook in the slots in the outer edge of the ring and pulling ring from box.
4. Remove all foreign matter from stuffing box.
5. An alternate method of removing the packing and lantern ring is as follows: Remove the upper half casing. See VI—D 1, 2, 4, 5. Remove the packing and lantern ring from the stuffing box. This method permits the inspection of the shaft sleeve and the stuffing box bushing. If the shaft sleeves are found to be deeply grooved in the packing area, they should be replaced as it is only possible for the packing to do an efficient job when the sleeve surface is relatively smooth.
6. Install stuffing box packing as described in II—C.

VI—E. DISMANTLING OF PUMP.

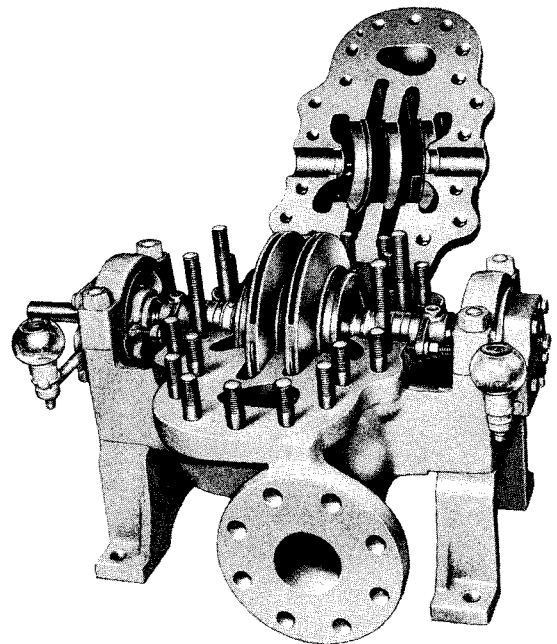
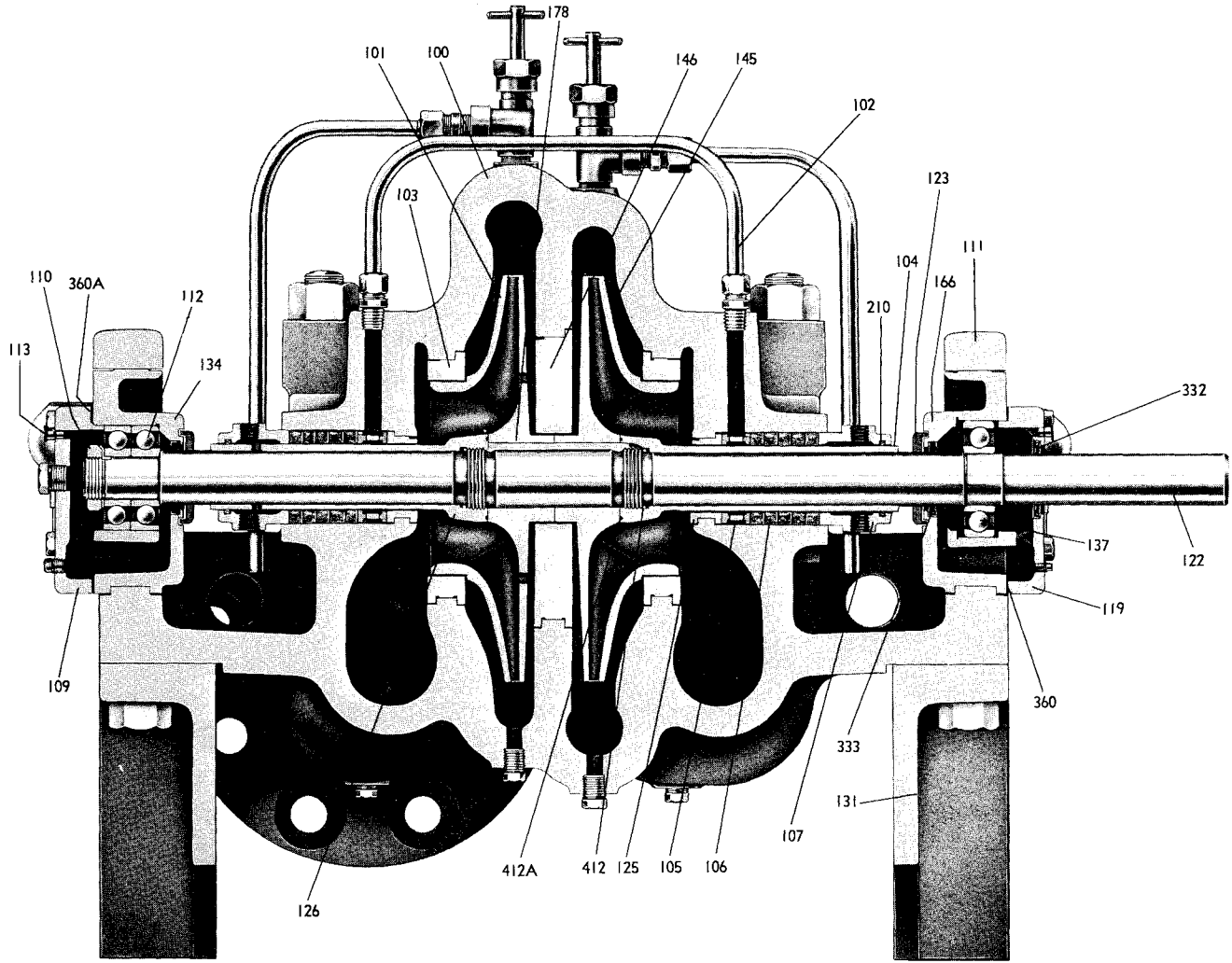

Figure 16

1. Drain liquid from pump.
2. Shut off and disconnect any auxiliary piping.
3. Disconnect coupling.
4. Remove gland assembly from stuffing boxes.
5. Jack and remove dowel pins from upper half casing by use of hex nut provided on

Section VI-C – Sectional View



Optional Constructions

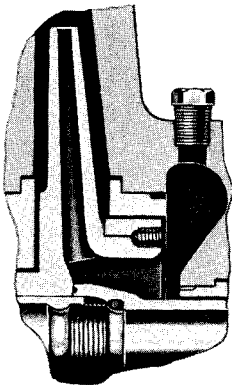

**Impeller
Wearing Ring**

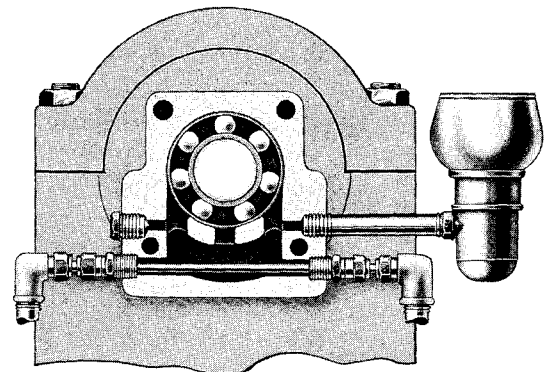

**Water Cooled
Bearing Construction**

Parts List and Interchangeability Chart

INTERCHANGEABILITY BY GROUP

Item No.	No. Req'd. Per Pump	PART NAME	PUMP SIZES →				MATERIAL											
			MATERIAL				Group S			Group M						Group L		
			Bronze Fitted	All Iron	All Bronze	316 St. Stl.	1½ × 2-9	2 × 3-9G	2 × 3-9	2 × 3-11	3 × 4-11G	3 × 4-11H	4 × 6-11HG	4 × 6-11	6 × 8-17	8 × 10-17		
100	1-Upper 1-Lower	Casing	1003	1003	1103	316	1½-9	2-9	2-11	3-11	4-11	6-17	8-17					
101	1	Impeller (Suction—1st Stage)	1103	1000	1103	316	1½-9	2-9	2-11	3-11	4-11	6-17	8-17					
102	1	Equalizing Pipe	Copper Tubing	Steel Tubing	Copper Tubing	316 St. St. Tubing	1			2						3		
103*	2	Wearing Ring—Casing	1106	1000	1106	316	*2	†	*3	†	*5	†	*6	*8	9			
104*	1	Shaft Sleeve—Locking	1106	AISI-420▼	1106	316	S	S	S	M	M	M	M	M	L	L		
105*	2	Lantern Ring	Teflon				S	S	S	M	M	M	M	M	L	L		
106*	1 Set	Stuffing Box Packing	Non-Asbestos				S	S	S	M	M	M	M	M	L	L		
107*	2	Stuff. Box Split Gland	1106	1000	1106	316	S	S	S	M	M	M	M	L	L			
109	1	Brg. End Cover—Thrust End	1000				S	S	S	M	M	M	M	M	L	L		
110	1	Shaft Nut and Lockwasher	Steel				S	S	S	M	M	M	M	M	L	L		
111	2	Bearing Cap	1000				S	S	S	M	M	M	M	M	L	L		
112	1	Ball Bearing—Thrust End	Steel				S	S	S	M	M	M	M	M	L	L		
113*	2	Oil Breather Fitting	Steel				M	M	M	M	M	M	M	M	M	M		
119	1	Brg. End Cover—Cplg. End	1000				S	S	S	M	M	M	M	M	L	L		
122	1	Shaft	SAE-4340	316	316		S	S	S	M	M	M	M	M	L	L		
123*	2	Deflector	Glass Impregnated Nylon				S	S	S	M	M	M	M	M	L	L		
125*	2	Stuffing Box Bushing	1102	1000	1102	316	S	S	S	M	M	M	M	M	L	L		
126*	1	Shaft Sleeve	1106	AISI-420▼	1106	316	S	S	S	M	M	M	M	M	L	L		
127‡	2	Wearing Ring—Casing	1106	1000	1106	316	*2A	*3	*3A	*5	*5A	*6	*6A	*8A	9A			
131	2	Pedestal	1000				S-1	S	S	M	M	M	M	M	L	L		
134	1	Bearing Housing—Thrust End	1000				S	S	S	M	M	M	M	M	L	L		
137*	1	Ball Bearing—Cplg. End	Steel				S	S	S	M	M	M	M	M	L	L		
142	2	Wearing Ring—Impeller	1103	1000	1103	316	*2	2A	*3	3B	*5	*6A	*6	*8	9			
145	1	Impeller—(Discharge 2nd Stage)	1103	1000	1103	316	1½-9	2-9	2-11	3-11	4-11	6-17	8-17					
146	1	Diaphragm	1106	1000(B)	1106	316	S-1	S-2	S-2	M	M	M	M	M	L	L		
166	1	Bearing Housing—Cplg. End	1000				S	S	S	M	M	M	M	M	L	L		
178*	1	Impeller Key	AISI-303				S	S	S	M	M	M	M	M	L	L		
190	2	Oiler Pipe	Steel				S	S	S	M	M	M	M	M	L	L		
210*	1 Set	Gland Packing	½" x ¼" Non-Asbestos				S	S	S	M	M	M	M	M	L	L		
251*	2	Constant Level Oiler	White Metal & Glass				M	M	M	M	M	M	M	M	M	M		
320*	6	Set Screw (Imp. Wrg. Ring)	AISI-303				L	L	L	L	L	L	L	L	L	L		
332*	1	Oil Seal—Brg. End Cover	Synthetic Rubber				S	S	S	M	M	M	M	M	L	L		
333*	2	Oil Seal—Brg. Housing	Synthetic Rubber				S	S	S	M	M	M	M	M	L	L		
351	1	Gasket—Casing Parting (Not Illus.)	½" Non-Asbestos															
353*	4	Gland Bolt (Not Illus.)	AISI-303				M	M	M	M	M	M	M	M	M	M		
354*	4	Gland Holding Washer (Not Illus.)	AISI-416				M	M	M	M	M	M	M	M	M	M		
355*	4	Gland Bolt Nut (Not Illus.)	AISI-303				M	M	M	M	M	M	M	M	M	M		
360	1	Gasket—Brg. End Cov.—Cplg. End	Manila Paper				S	S	S	M	M	M	M	M	L	L		
360A	1-3	Gasket—Brg. End Cov.—Thrust End	Manila Paper				S	S	S	M	M	M	M	M	L	L		
412*	2	"O" Ring—Shaft	Buna Rubber				S	S	S	M	M	M	M	M	L	L		
494	2-Assem.	Bearing Cooling Coil	Brass				M	M	M	M	M	M	M	M	M	M		

*Are interchangeable with Goulds Model 3405 Double Suction Single Stage Pumps

†On these sizes, impeller wearing rings are standard.

‡Used when impeller is furnished with wearing rings.

⊙Used when impeller is furnished without wearing rings.

•Sizes 1½ × 2-9, 2 × 3-9G, 2 × 3-11 & 3 × 4-11G, not available in steel or stainless steel.

▼Flame hardened to 550 Brinell

(B)Ductile Iron on Group "L".

Materials of Construction

No.	Cu %	Sn %	Pb %	Zn %	P %	Ni %
1102	84-86	4-6	4-6	4-6	—	—
1103/ 1106	87	6	4.5	1.75	.05-.15	0.75

1000—Cast Iron—Corresponds to ASTM A48 Class 25
1003—Cast Iron—Corresponds to ASTM A48 Class 30

Construction Details

	Group S			Group M				Group L		
	1 1/2 x 2-9	2 x 3-9G	2 x 3-9	2 x 3-11	3 x 4-11G	3 x 4-11H	4 x 6-11HG	4 x 6-11	6 x 8-17	8 x 10-17
Impeller	Weight-Bronze Fitted Bare Pump in Lbs.									
	Weight-Bronze Impeller (Suction-1st Stage) Max. Dia. in lbs.									
	Weight-Bronze Impeller (Disch.-2nd Stg.) Max. Dia. in lbs.									
	Maximum Diameter Solids									
Casing	Casing Thickness—Volute									
	Casing Thickness—Side Walls									
	Minimum Casing Corrosion Allowance									
	Casing Capacity—Gallons (with Pump Assembled)									
Stuffing Box	Stuffing Box Bore									
	Stuffing Box Depth (To stuff. Box Bushing)									
	Stuffing Box Packing Size									
	Stuffing Box—No. of Packing Rings									
	Width of Lantern Ring									
Shaft	Shaft Dia. at Impellers									
	Shaft Dia. at Shaft Sleeve									
	Shaft Dia. at Coupling End									
	Outside Diameter of Shaft Sleeve									
General	Ball Bearing—Coupling End									
	Ball Bearing—Thrust End									
	Bearing Centers									
	Maximum Shaft H. P. Per 100 RPM									
Press. Temp. Limits	†Maximum Total Working Pressure									
	Maximum Test Pressure									
	Max. Liquid Temp. without Cooling or Quenching									
	Max. Liquid Temp. with Quenching Gland and Bearing Cooling									

†Maximum suction pressure is 240 PSIG.

*Gland quenching recommended on hot water above 212° F

Pressure & Temperature Capability

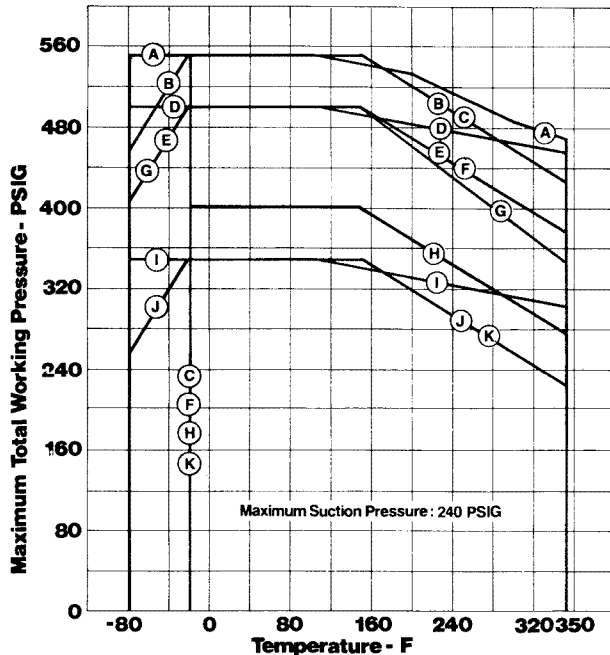

Code for Pressure - Temperature Chart

Group	Curve	Casing Material	Acceptable Minimum Standard ANSI Mating Flanges and Fittings	
			Suction	Discharge
M	A	316 SS	300 PSI Flat Face 316 SS	300 PSI Flat Face 316 SS
	B	Bronze	300 PSI Flat Face Bronze	
	C	CI	250 PSI Flat Face Cast Iron	
S	D	316 SS	300 PSI Flat Face 316 SS	300 PSI Flat Face 316 SS
	E	Bronze	300 PSI Flat Face Bronze	
	F	CI	250 PSI Flat Face Cast Iron	
L	I	316 SS	300 PSI Flat Face 316 SS	300 PSI Flat Face 316 SS
	J	Bronze	300 PSI Flat Face Bronze	300 PSI Flat Face Bronze
	K	CI	250 PSI Flat Face Cast Iron	250 PSI Flat Face Cast Iron
M & S	G	Bronze	300 PSI Flat Face Bronze	300 PSI Flat Face Bronze
		CI	250 PSI Flat Face Cast Iron	250 PSI Flat Face Cast Iron

E 2166 A, Rev. 1

VI—F. OVERHAUL OF PUMP.

The following items should be checked:

1. Wearing Ring Clearance:

The original diametral clearance between the impellers and case wearing rings for different materials is shown on Fig. 18 (dwg. 108-47). Clearance between casing wearing rings and optional impeller wearing rings is also shown. When hydraulic performance is reduced substantially, the casing rings and/or impeller rings should be replaced.

The diametral clearance on one impeller should not exceed the clearance on the other impeller in the same pump by more than .003".

2. Impeller Wearing Rings:

If the unit has impeller wearing rings and it is necessary to replace the rings:

a) Remove old rings by removing the three

set screws and pulling ring off hub.

b) Clean hub and press on new ring.

c) Drill and tap three holes 120° apart in each ring. Use "F" drill $\frac{13}{16}$ " deep with $\frac{5}{16}$ " — 18 NC taps $\frac{3}{8}$ " deep. Use $\frac{5}{16}$ " x $\frac{5}{16}$ " cup point safety set screws. Tighten screws and lightly "upset" threads. See Fig. 18.

d) Replacement impeller rings are supplied .021" to .039" oversize and must be turned to size after mounting on impeller. See Fig. 18 for dimensions.

3. Fit of Impeller on Shaft:

The impellers should tap easily on the shaft. If the impellers do not tap on readily, the bore and shaft should be inspected to see that they are free from foreign matter or burrs. The fit of the key in the keyways should also be checked to see that it is not causing binding. See Fig. 18.

NOTES:

- REPLACEMENT IMPELLER RINGS ARE FURNISHED .021" TO .039" OVERSIZE AND MUST BE TURNED TO SIZE AFTER MOUNTING ON IMPELLER. SEE WEARING RING CHART BELOW.
- THE DIAMETRAL CLEARANCE ON ONE IMPELLER SHOULD NOT EXCEED THE CLEARANCE ON THE OTHER IN THE SAME PUMP BY MORE THAN .003".
- THE FIT OF THE IMPELLER HUBS ON THE SHAFT (NOT ILLUSTRATED) IS A TAP TO A SLIP FIT PER CHART BELOW.
- THE IMPELLER KEY HAS A SLIDING FIT ON THE SIDES AND A .008" TO .016" CLEARANCE AT THE TOP (NOT ILLUSTRATED).
- THE INITIAL DIAMETRAL CLEARANCE OF THE SHAFT SLEEVES TO THE THROAT BUSHINGS IS .020" TO .024" (NOT ILLUSTRATED).

GROUP	FIT OF IMPELLER HUB TO SHAFT ON DIAMETER	
	IRON OR BRZ. IMPELLER	STEEL IMPELLER
S	-.0003 / -.0013	
M		-.0002 / +.0008
L	-.0002 / +.0008	

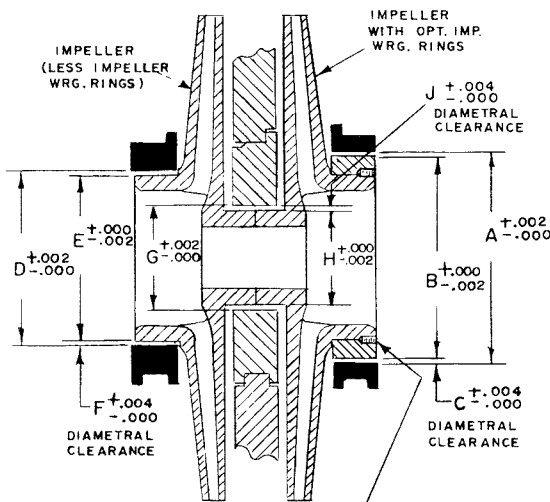

(3) DRILLS SIZE "F", $\frac{13}{16}$ " DEEP.
120° APART, $\frac{5}{16}$ "-18 NC TAPS, $\frac{3}{8}$ " DEEP
FOR $\frac{5}{16}$ " x $\frac{5}{16}$ " CUP POINT SAFETY SET
SCREWS #49514 - 227 UPSET THREADS.

INITIAL WEARING RING CLEARANCES

CONDITION	X	PUMP SIZE							
		1/2x2-9	2x3-9	2x3-11	3x4-11H	4x6-11	4x6-11HG	6x8-17	8x10-17
IRON OR BRONZE IMPELLER RINGS & CASE RINGS	A	3.875	4.875	4.875	5.875	7.000	6.382	8.500	10.248
	B	3.859	4.859	4.859	5.858	6.982	6.364	8.480	10.226
	C	.016	.016	.016	.017	.018	.018	.020	.022
STEEL IMPELLER RINGS & CASE RINGS	A		4.875		5.875	7.000	6.378	8.500	10.248
	B		4.859		5.858	6.982	6.360	8.480	10.226
	C		.016		.017	.018	.018	.020	.022
STL. CASE RINGS W/ IRON OR BRZ. IMPELLER RINGS	A		4.877		5.875	7.000	6.378	8.500	10.248
	B		4.859		5.858	6.982	6.364	8.480	10.226
	C		.016		.017	.018	.018	.020	.022
IRON OR BRZ. CASE RINGS W/ STEEL IMPELLER RINGS	A		4.875	4.875	5.875	7.000	6.382	8.500	10.248
	B		4.859	4.859	5.858	6.982	6.360	8.480	10.226
	C		.016	.016	.017	.018	.022	.020	.022
IRON OR BRONZE CASE RING & IMPELLER	D	3.253	4.255	4.255	5.256	6.382		7.756	9.383
	E	3.239	4.239	4.239	5.239	6.364		7.737	9.362
	F	.014	.016	.016	.017	.018		.019	.021
STEEL CASE RING & IMPELLER	D		4.251		5.251	6.378		7.753	9.378
	E		4.235		5.235	6.360		7.734	9.357
	F		.016		.016	.018		.019	.021
STEEL CASE RINGS W/ IRON OR BRZ. IMPELLER	D		4.251		5.251	6.378		7.753	9.378
	E		4.239		5.239	6.364		7.737	9.362
	F		.012		.012	.014		.016	.016
IRON OR BRONZE CASE RING W/ STL. IMP.	D		4.255		5.256	6.382		7.756	9.383
	E		4.235		5.235	6.360		7.734	9.357
	F		.020		.021	.022		.022	.026

INITIAL DIAPHRAGM CLEARANCES

CONDITION	X	PUMP SIZE							
		1/2x2-9	2x3-9	2x3-11	3x4-11H	4x6-11	4x6-11HG	6x8-17	8x10-17
IRON OR BRONZE IMPELLER AND DIAPHRAGM	G	1.873	1.873	2.373	2.373	2.373	2.373	3.250	3.250
	H	1.865	1.865	2.365	2.365	2.365	2.365	3.238	3.238
	J	.008	.008	.008	.008	.008	.008	.012	.012
STEEL IMPELLER AND DIAPHRAGM	G		1.873		2.373	2.373	2.373	3.250	3.250
	H		1.857		2.357	2.357	2.357	3.234	3.234
	J		.016		.016	.016	.016	.016	.016
STEEL IMPELLER WITH IRON OR BRZ. DIAPHRAGM	G		1.873		2.373	2.373	2.373	3.250	3.250
	H		1.857		2.357	2.357	2.357	3.234	3.234
	J		.016		.016	.016	.016	.016	.016
IRON OR BRONZE IMPELLER WITH STL. DIAPHRAGM	G	1.873	1.873	2.373	2.373	2.373	2.373	3.250	3.250
	H	1.665	1.665	2.365	2.365	2.365	2.365	3.238	3.238
	J	.008	.008	.008	.008	.008	.008	.012	.012

Figure 18

4. Clearance Between Shaft Sleeve (104 or 126) and Stuffing Box Bushing (125): The original diametric clearance is .020" to .024" for all materials. If progressive wear contributes to a decrease in performance and/or excessive leakage through the stuffing box, the shaft sleeve and, at times, the stuffing box bushing should be replaced.
5. Condition of Shaft Sleeves: If the outer surface of the shaft sleeve at the packing area is deeply grooved, the sleeve should be replaced.
6. Conditions of Shaft: Check shaft for straightness. If bent, it should be straightened. If otherwise damaged, it should be replaced.
7. Condition of Impellers: Check the impellers and replace if any of the following conditions exist:
 - a) Excessive erosion, especially on the inlet of vanes.
 - b) Excessive wear on wearing surfaces.
8. Condition of Ball Bearings: If the bearings are worn or damaged so that they have become loose or are noisy or rough when rotated, they should be replaced.
9. Clearance Between Impeller Hub & Diaphragm: The original diametric clearance between the impeller and diaphragm is shown in Fig. 18. When performance is substantially reduced, or when the diametral clearance exceeds 0.035", the diaphragm and, at times, the impeller should be replaced.

VI—G. REASSEMBLY OF PUMP.

The following directions are for use when the pump is completely dismantled and it is desired to reassemble. See III. C.

1. If the impeller diameters have been cut in the field, the impellers should be statically balanced and, if possible, dynamically balanced. Balancing can be effected by grinding on the outside of the shrouds near the periphery.
2. Determine the correct setting of the impellers and sleeves on the shaft in relation to the rotation of the pump. To do this, face the discharge flange of pump. The locking shaft sleeve (104) (sleeve with keyway) must be on the right as shown in Fig. 19 and the impellers must rotate in correct relation to the casing as shown in the end views in Fig. 19.
3. Mark the location of the keyways on the outside of both the second stage impeller hub (145) and the locking sleeve (104) at points "A" and "B" in Fig. 20 and 21. These marks will be used later to indicate that the keyways are in line.

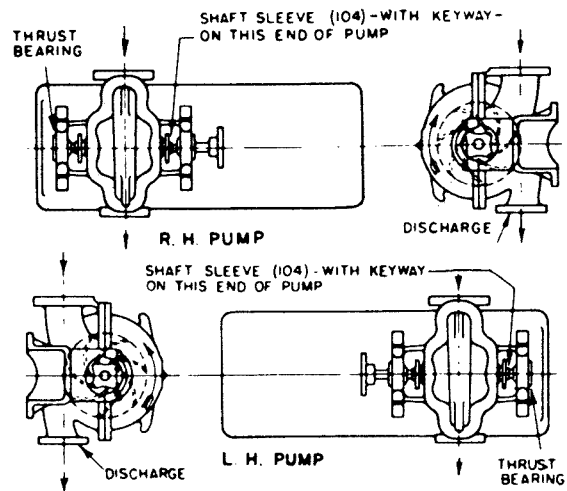

78-67

Figure 19

4. Assemble the shaft sleeve (104) that has keyways in the threaded end but does not have spanner wrench holes. Turn sleeve in a clockwise direction on shaft until the dimension from the threaded end of the sleeve to the shaft shoulder at thrust bearing or outboard seat agrees with the dimension on Fig. 21 for right hand or Fig. 20 for left hand rotation. This dimension must be held as near as possible with the keyways in the shaft and sleeve in alignment.
5. Insert impeller key (178) in shaft keyway. Turn sleeve (104) about a quarter turn, either way, so that key cannot enter keyway in this sleeve until after impellers are checked for correct setting in casing.
6. Replace "O"-Ring (412A) in groove in end of shaft sleeve (104). "O"-Ring may have to be slightly stretched to fit.
7. Slide second stage or discharge impeller (145) on shaft and tap in place against the sleeve with a lead mall.
DO NOT TAP AGAINST THE SEALING SURFACE ON END OF HUB.
8. Slide diaphragm (146) over shaft and up against impeller (145).
9. Slide first stage or suction impeller (101) on shaft and tap in place against second stage or discharge impeller (145).
10. Place "O"-Ring (412A) in groove in end of shaft sleeve (126). Screw shaft sleeve on shaft up to key.
11. Slip wearing rings (103 or 127) on impeller, being sure that the single lock on the

upper half of rings is toward the center of impellers.

12. Place stuffing box bushings (125) on shaft and slide over shaft sleeves toward impeller. The single lock on the upper half of bushings must be toward the outside, away from impeller.
13. If oil seals (332 or 333) are being replaced, make sure that the seals are installed so that the lips of the seals face inward, toward the bearings.
14. Make sure that all parts that are assembled inside the bearing housings, including the shaft, shaft nut, bearing end covers, and bearings, are entirely free from dust and dirt.
This is extremely important, as the life of a ball bearing can be drastically reduced if contaminated with even a small amount of dirt. All bearing assembly operations should be done in as dust-free an atmosphere as possible. All tools, as well as the hands, should be kept clean.
If new ball bearings are being used, they should not be unwrapped until ready for installation and should not be cleaned or washed unless the protective wrapper has been broken and dirt allowed to enter the bearings.
If old bearings, or new ones that have been allowed to become dirty, are being used, clean thoroughly before installing as follows: Use a clean pail or receptacle. Pour into it one or two quarts of clean, water-free kerosene. Dip the bearing into the kerosene and spin slowly. Repeat until all traces of grease have been removed. Now blow dry with clean filtered compressed air, holding the two races together so that they do not rotate but allowing the inner race to rotate a few turns now and then to dislodge the kerosene from the retainer pockets. If the bearing is very dirty it is advisable to rinse it in a second bath of clean kerosene. When the bearing has been blown dry, oil it immediately with a good grade of clean machine oil; especially the race grooves and balls to prevent corrosion or rust. If there is any question about the condition of the bearings, it is best to replace them. This may prevent an unplanned shut-down.
15. Place deflectors (123) on shaft.
16. Wipe a small amount of grease on the oil seal lips. Place bearing housings (134 and 166) on shaft and slide them along until they contact the shaft sleeves. Care must be taken not to injure the lips of the oil seals during this operation. A thin piece of shim stock, wrapped inside the oil seal before

sliding over the shaft will protect the seal lips and can readily be removed after the seal is past the shaft shoulder.

17. Coupling end bearing is single row. Thrust bearing is a duplex bearing (two angular contact bearings, specially matched) and must be mounted in "back-to-back" position. This is done on the bearings originally sent with the pump by having the stamped faces of the outer rings against each other.
18. Although the thrust and coupling end ball bearings are different, they are installed in a like manner as follows: Apply a film of oil to the bearing seat on the shaft. Start bearing "square" and drive on about $\frac{1}{8}$ ", keeping bearing square at all times. Use a driving sleeve as shown in Figs. 19 and 20. Note that the outside diameter of this sleeve should never be larger than the outside diameter of the inner race of bearing. Next slip the bearing housing over the ball bearing toward the end of the shaft to eliminate any possibility of binding between the outside of the bearing and the bearing housing bore. Now continue to drive the bearing solidly against the shaft shoulder.
19. Screw shaft nut (110) on shaft and tight against bearing (112).
20. Oil shaft extension and slide coupling end bearing end cover (119) on shaft with gasket (360) in place, being careful not to injure oil seal (332). Turn end cover so that the small oil cup is up when the double locks of the bearing housing are in the lowermost position (see Figs. 19 and 20). This oil cup is used as a pressure relief for the bearing housing. It must be in the vertical position or the bearing will not be properly oiled. Be sure gasket (360) is in place. Bolt the end cover to the bearing housing.
21. Assemble the pump half coupling as follows: Put oil or white lead on shaft extension and in the coupling bore. Insert pump half coupling key in shaft. Place the complete pump half coupling over end of shaft and align key with keyway. Place a solid object, such as portion of a 2" diameter bar, against the end of the shaft opposite the coupling end drive coupling half on shaft with a lead mallet. Note: If a bearing puller, similar to that shown in Fig. 17 is available, it can be used on thrust bearing end to hold shaft when driving on coupling half. When using the puller for this purpose, draw the puller screw up only finger tight. Locate the coupling half in the same location on shaft as it was when removed.

Never drive the coupling on shaft with the thrust end bearing end cover (109) in place as this may injure the ball bearing.

22. Bolt the thrust end bearing end cover (109) to the bearing housing. Be sure gasket (360A) is in place. Be sure relief fitting is up as indicated in VI—G, Step 20. Note: From one to three gaskets (360A) are used to secure the proper thrust bearing end play. Because of machining tolerances, a replacement thrust bearing may vary in width by as much as 0.020". End play must be checked and adjusted by adding or removing gaskets as described in VI—G, Step 30.
23. Smooth up and clean casing wearing ring, diaphragm, stuffing box bushing and bearing housing seats in upper and lower half casing. The casing and bearing caps are precision bored so that hand scraping and fitting of the casing wearing rings, diaphragm, stuffing box bushings or bearing housings are not required. Inspect gasket and if torn or otherwise damaged, cut a new gasket. The gasket should be removed while installing the rotating element in the casing.

To cut a new gasket, lay the gasket sheet on the upper half casing parting flange, which will serve as a template. Strike the sheet with a ball peen hammer. This will cut the gasket against the edges of the casting, and around the parting stud holes. The gasket must cover the entire surface of the parting flange, especially around the casing wearing ring locks, or internal leakage from high to low pressure zones in the pump may occur.

24. Lower carefully the entire rotating element into the lower half casing. Be sure that the wearing rings, diaphragm, stuffing box bushing and bearing housing "locks" line up with the recesses in the lower half casing. The double "locks" on each of these parts must be on the bottom so that when the upper half casing and the bearing caps, having only one recess each, are bolted in place, these parts are locked against rotation.

With "locks" properly aligned, the rotating element should settle easily into place. If there is interference, the impeller may have to be tapped along the shaft until it lines up correctly. The sleeves may have to be backed off to do this.

After the element has been properly seated in the lower half casing, check the clearance at "C" and "D". (See Figs. 19 and 20.) The clearance at "C" and "D" should be equal.

Now tighten shaft sleeve (104) against impeller until the marks, which were made previously, line up indicating that the keyways are in line. Check again the distances "C" and "D". If rubbing occurs, turn the shaft sleeve (104) one half of a turn or a complete turn ahead or back as required. With the locating marks together, tap the key (178) into the shaft sleeve (104) until the end of the key is flush with the end of the impeller hub (101).

Tighten the shaft sleeve (126) securely against the impeller with a spanner or a strap wrench and tighten the set screw in the sleeve.

25. Check the rotating element for free turning by rotating slowly in one direction and then the other. The casing rings and the stuffing box bushings should be seated in the lower half casing, and should remain stationary when the shaft is rotated. If they ride on the impeller or sleeves, it may indicate that the bearing housings, wearing rings or bushing surfaces in the lower half casing have not been properly cleaned of scale or other foreign matter, or that there is too much eccentricity in the element, due to a bent shaft or other causes. If any of the above are evident, correct the cause and continue to assemble as follows.
26. Assemble bearings caps (111) and tighten the nuts evenly, being sure that the bearing caps are replaced on the same end from which they were removed.
27. Check again for free turning of the rotating element.
28. Place the parting gasket in position over the studs on the lower half casing with the edge flush with the stuffing box bores and tight against the wearing rings and stuffing box bushings.
29. Be sure that the "locks" on the stuffing box bushing and wearing rings are in their correct position with the single "locks" on top. Lower carefully the upper half casing, which should settle into position without resistance. Slip the dowel pins in place. Check the rotating element for free turning and, if no binding is apparent, tighten casing parting nuts alternately on each side of the pump starting from the center. The shaft should turn freely after all nuts are tightened.
30. Clamp an indicator to the pump so that the button rests against the end of the shaft. Push the shaft back and forth as far as

possible. Total end play MUST be AT LEAST 0.001", and NOT MORE THAN 0.008". If end play is less than 0.001", add thrust end bearing end cover gaskets (360A) made from 0.006" thick Vellumoid paper. If end play is greater than 0.008", remove gaskets. Because of machining tolerances, thrust bearings may vary in width by 0.020". A correctly assembled pump may require as few as one, or as many as three, 0.006" thick gaskets.

31. Repack stuffing boxes and replace gland assemblies as outlined in II—C.
32. Check coupling alignment as outlined in I—C (page 2).
33. Connect coupling as outlined in I—J.
34. Oil pump bearings as outlined in II—A.
35. Connect auxiliary piping.
36. Follow directions in Section III for initial operating conditions and for starting pump.

VI—H. CHANGING ROTATION OF PUMP IN FIELD.

The rotation of these pumps can be changed without using additional parts. The following steps should be followed:

1. Disassemble pump as outlined in VI—E
2. Loosen dowel pins, if used, in pump feet and remove hold-down bolts. Lift lower half casing from bedplate.
3. Turn lower half casing 180° so that suction and discharge flanges are reversed from previous position or turn bedplate 180° and leave pump casing in original position. See Fig. 18, showing right and left hand pump.
4. Replace lower half casing in this new position on bedplate and bolt in place. Do not dowel.
5. Reassembly pump as outlined in VI—G, for new direction of rotation.

VI—I. EMERGENCY BALL BEARING REPLACEMENT.

If the thrust end ball bearing (112) has become worn and needs replacing and it is not desirable to overhaul the entire pump, the bearing can be replaced as follows:

NOTE: This cannot be done on the coupling end unless the pump or the driver is removed from the bedplate, or unless a spacer coupling is used.

1. Remove constant level oiler from thrust end bearing housing (134). Drain oil from housing.
2. Remove thrust bearing end cover (109).
3. Remove shaft nut (110).

4. Remove bearing cap (111).
5. Rotate bearing housing (134) 180° so that the two locks are on the top.
6. Remove ball bearing as directed in VI—E, 13 and 14.
7. Thoroughly flush bearing housing, bearing end cover, shaft nut and end of shaft with clean kerosene. The slightest trace of dirt or grit may drastically reduce the life of a ball bearing.

Examine the shoulder on the shaft against which the ball bearing bears. Shoulder must be square, and not rounded over.

8. Assemble new ball bearing as follows:
 - (a) Wipe a small amount of grease on the oil seal lips in the bearing housing.
 - (b) Place bearing housing on shaft, with the double locks up, and slide it along to approximately its correct location.
 - (c) Apply a film of oil to the bearing seat on the shaft. Start bearing "square" and tap on shaft up to the shaft shoulder. Use a driving sleeve as shown in Fig. 19 and 20.
 - (e) Screw shaft nut (110) tight against bearing.
 - (f) Align locks on bearing end cover with the grooves in lower half casing and rotate bearing end cover 180° so that the locks are at the bottom.
 - (g) Bolt bearing end cover (109) to bearing housing. Be sure gasket (360) is in place. Position end cover as directed in Section VI—G, Step 20 so that relief fitting is in correct location.
 - (h) Assemble bearing cap (111) being sure that the prick punch marks on the cap and the casing are on the same side. Now tighten the nuts evenly.
 - (i) Check thrust bearing end play, as directed in Section VI—G, Step 30.
 - (j) Refill with oil as outlined in II—A.

VI—J. SPARE PARTS.

To insure against possible long and costly "down-time" periods, especially on critical services, it is advisable to have spare parts on hand.

1. The most desirable parts to have on hand are the following:
 - (a) "Rotating element." This is a group of assembled parts, including bearing housings, bearings, bearing end covers, oil seals, wearing rings, diaphragm, stuffing box bushings and all rotating parts, except coupling.
 - (b) Stuffing box packing (106) — one set for two stuffing boxes.
 - (c) Stuffing box gland packing (210) — one set for four gland halves.

(d) Stuffing box gland halves (107) — four required.

With these parts on hand, pump can be easily and quickly reconditioned by replacing the worn parts.

2. An alternate, though not as desirable as that stated above, is to have on hand parts that are most likely to wear and which can be used as needed.

Following is a list of these suggested parts:

(a) Stuffing box packing (106) — one set for two stuffing boxes.

(b) Stuffing box gland packing (210) — one set for four gland halves.

(c) Shaft sleeve (104 and 126) — one each.

(d) Ball bearings (112 and 137) — one of each.

(e) Shaft nut (110) — one required.

(f) Wearing rings (103) — two required; or (127 and 142) two of each.

(g) Diaphragm (146) — one required.

(h) Shaft (122) — one required.

(i) Impeller key (178) — one required.

(j) Stuffing box bushings (125) — two required.

(k) Stuffing box gland halves (107) — four required.

3. If it is not convenient or desirable to carry the spare parts listed in items 1 or 2, the following list is suggested as a minimum for

servicing the pump under ordinary conditions of wear:

(a) Stuffing box packing (106) — one set for two stuffing boxes.

(b) Stuffing box gland packing (210) — one set for four gland halves.

(c) Shaft sleeves (104 and 126) — one each.

(d) Ball bearings (112 and 137) — one of each.

(e) Shaft nut (110) — one required.

VI—K. INSTRUCTIONS FOR ORDERING SPARE PARTS.

Repair orders will be handled with the minimum of delay if the following directions are followed:

1. Give Model No., size of the pump and serial number. These can all be obtained from the name plate.
2. Write plainly the names, part numbers and material of the parts required. These names and numbers should agree with those on the sectional assembly (Section VI—C).
3. Give the number of parts required.
4. Give complete shipping instructions.

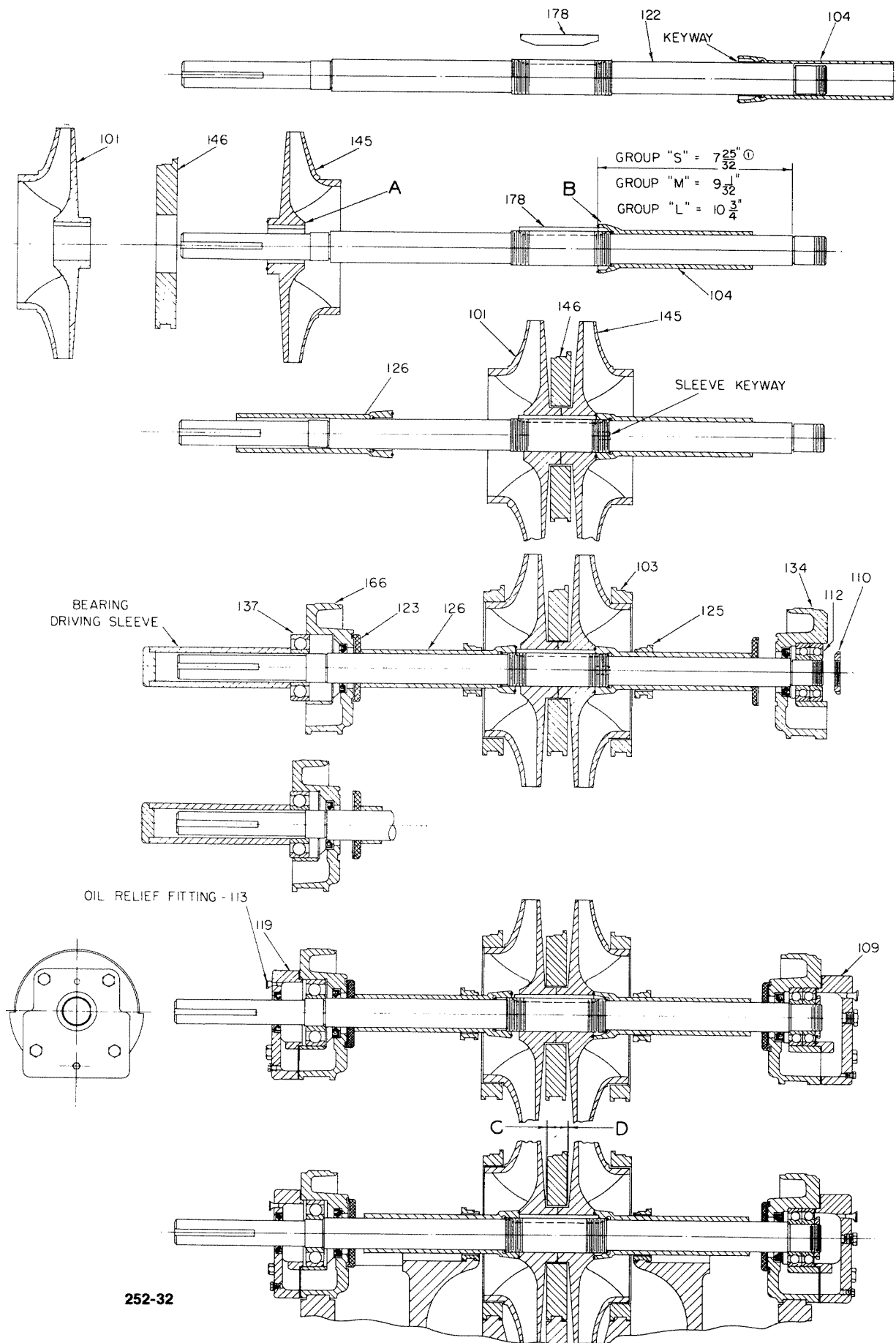
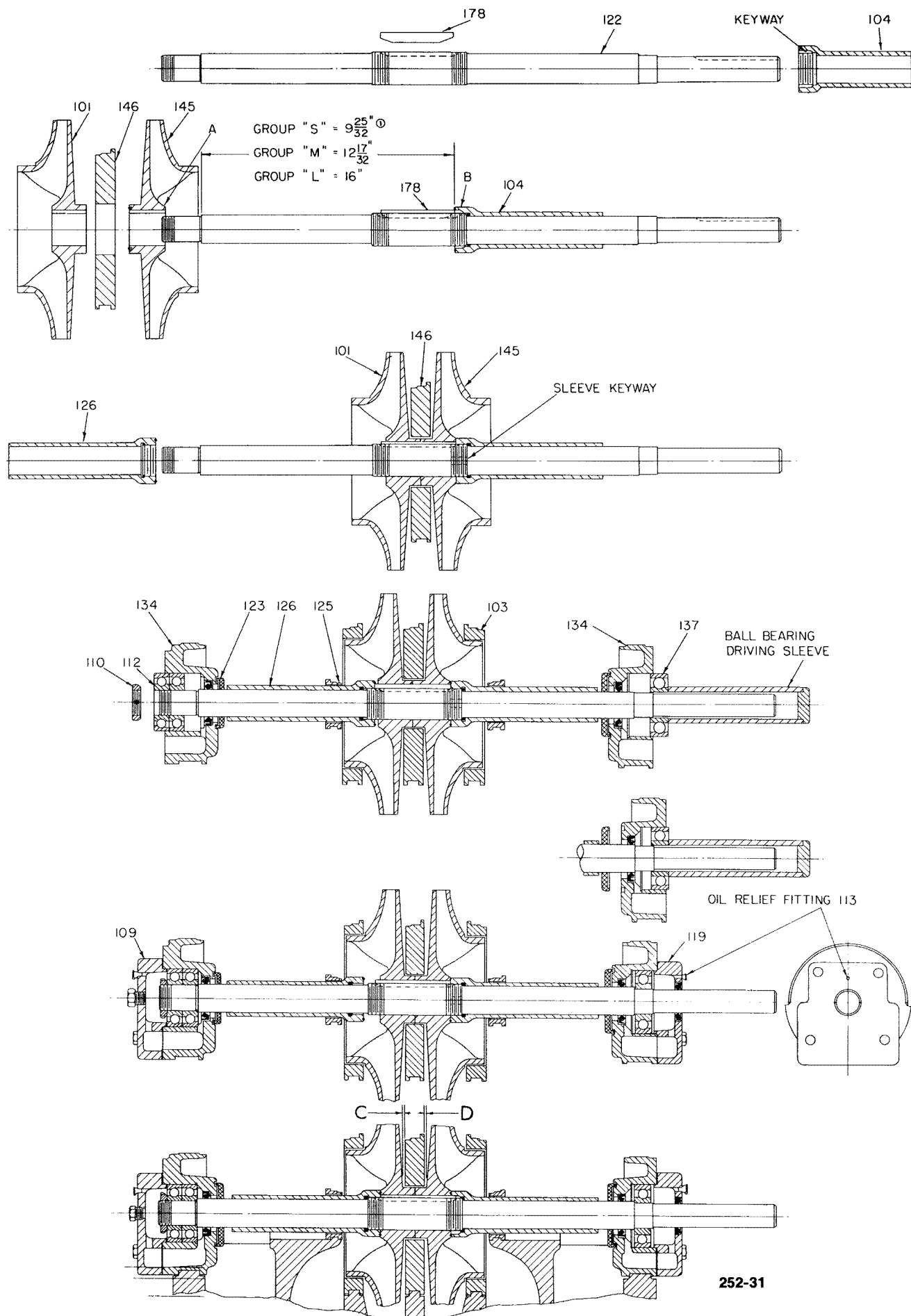

Figure 20 LEFT HAND PUMP



RIGHT HAND PUMP **Figure 21**

A pump is only as good as its parts.

The Goulds pump featured in this instruction manual is made up of many different parts. All are engineered and precision manufactured to make the pump perform as intended. Therefore it's *most important* to make sure that you use only genuine Goulds replacement parts.

To assure that you can make no better choice than Goulds, we offer the best pump parts program in the industry. We call it "pump parts like never before" and very simply means unsurpassed *availability, service, quality and value.*



Availability A nationwide, computer-controlled distribution network backed by factory programs designed to get you the part you need — when you need it.



Quality Goulds is committed to providing the highest *original* quality and sometimes *better* if design or material improvements have been made.

Service Our Certified Original Parts specialists are dedicated to serving your parts needs by:

- Helping minimize parts inventories
- Delivering parts
- Providing maintenance consultation service

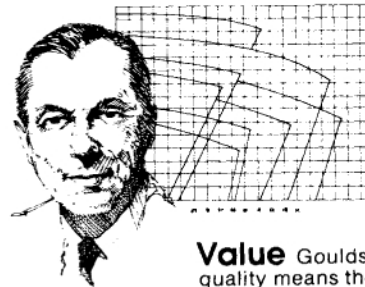

Value Goulds high standards of quality means the part will fit right and meet original standards of performance.



For more information, call your nearest Goulds sales representative or visit our website at www.gouldspumps.com.



ITT