

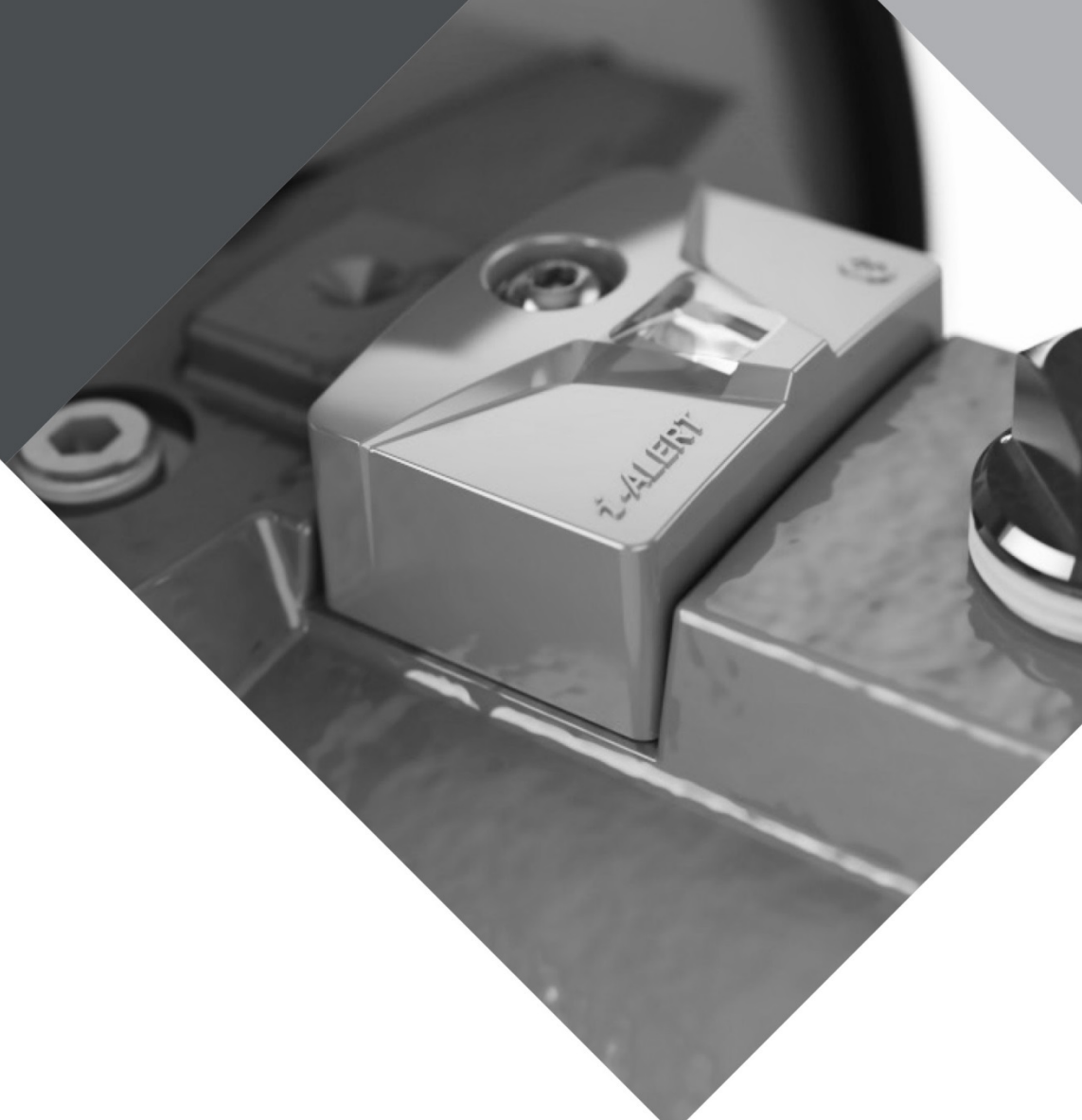

Installation, Operation, and Maintenance Manual

i-ALERT^{®2} Equipment Health Monitor



ITT

ENGINEERED FOR LIFE

Table of Contents

Introduction and Safety	3
Introduction	3
Requesting other information	3
Inspect the package	3
Limited warranty	3
Safety	4
Safety terminology and symbols	4
Safety regulations for Ex-approved products in potentially explosive atmospheres	5
Product approval standards	5
Product Description	9
General description i-ALERT [®] 2 Equipment Health Monitor	9
Installation	10
Attach the i-ALERT ² Equipment Health Monitor to the pump	10
Commissioning, Startup, Operation and Shutdown	11
Activate the i-ALERT ² Equipment Health Monitor	11
Reset the i-ALERT ² Equipment Health Monitor	12
i-ALERT ² Equipment Health Monitor routine operation	13
Maintenance	13
Guidelines for disposal of i-ALERT ² Equipment Health Monitor	13
Troubleshooting	14
i-ALERT ² Equipment Health Monitor troubleshooting	14

i-ALERT®2 Equipment Health Monitor Installation, Operation and Maintenance Manual

Introduction and Safety

Introduction

Purpose of this manual

The purpose of this manual is to provide necessary information for:

- Installation
- Operation
- Maintenance



CAUTION:

Read this manual carefully before installing and using the product. Improper use of the product can cause personal injury and damage to property, and may void the warranty.

NOTICE:

Save this manual for future reference, and keep it readily available at the location of the unit.

Requesting other information

For instructions, situations, or events that are not considered in this manual or in the sales documents, please contact your ITT representative. Always specify the exact product type and identification code when requesting technical information or spare parts.

Inspect the package

1. Inspect the package for damaged or missing items upon delivery.
2. Note any damaged or missing items on the receipt and freight bill.
3. File a claim with the shipping company if anything is out of order. If the product has been picked up at a distributor, make a claim directly to the distributor.

Limited Warranty

Goulds Pumps, Inc. ("Goulds") warrants to the original purchaser that your i-ALERT®2 Equipment Health Monitor (the "Product") shall be free from defects in materials and workmanship under normal use for a period of one (1) year from the date of shipment. This Limited Warranty does not cover software embedded in the Product and the services provided by Goulds to owners of the Product.

Due to the varied ways that Product(s) can be access and/or configured during use, battery life is excluded from warranty. It is your responsibility to backup any data, software, or other materials you may have stored or preserved on the Product. It is likely that such data, software, or other materials will be lost

or reformatted during service, and Goulds will not be responsible for any such damage or loss. Recovery and reinstallation of software programs and user data are not covered under this Limited Warranty. The Limited Warranty does not apply to any software, even if packaged or sold with the Product or embedded in the Product. We are not liable for any damage a mobile app may inflict on companion product.

To view the full details of the Limited Product Warranty please go to: www.i-alert.com/warranty

Safety

WARNING:

- The operator must be aware of safety precautions to prevent physical injury.
- Operating, installing or maintaining this unit in any way that is not covered in this manual could cause death, serious personal injury, or damage to the equipment. This includes any modification to the equipment or use of parts not provided by ITT. If there is a question regarding the intended use of the equipment, please contact an ITT representative before proceeding.
- Installation, Operations and Maintenance manuals clearly identify accepted methods for disassembling units. These methods must be adhered to.

Observe all safety messages highlighted in other sections of this manual

Safety Terminology and symbols

About safety messages

It is extremely important that you read, understand and follow the safety messages and regulations carefully before handling the product. They are published to help prevent these hazards:

- Personal accidents and health problems
- Damage to the product
- Product malfunction

Hazard levels

Hazard level	Indication
Danger:	A hazardous situation which, if not avoided, will result in death or serious injury
Warning:	A hazardous situation which, if not avoided, could result in death or serious injury

Safety regulations for Ex-approved products in potentially explosive atmosphere

Description of ATEX

The ATEX directives are a specification enforced in EU for electrical and non-electrical equipment. ATEX deals with the control of potentially explosive atmospheres and the standards of equipment and protective systems used within these atmospheres. The relevance of the ATEX requirements is not limited to Europe. You can apply these guidelines to equipment installed in any potentially explosive atmosphere.

Description of ETL

The ETL Mark is proof of product compliance to North American safety standards. Authorities Having Jurisdiction(AHJs) and code officials across the US and Canada accept the ETL Listed Mark as proof of product compliance to published industry standards.

Description of IECEx

The IECEx certificates of conformity attest that a sample of the Ex product, have been independently tested and found to comply with the International Standards. It also attests that the manufacturing site has been audited to verify that the manufacturer's quality system meets IECEx requirements.

Safety regulations regarding the Battery

Do not charge, short circuit, crush, disassemble, heat above 100°C (212°F), incinerate or expose contents to water.

Personal requirements

ITT disclaims all responsibility for work done by untrained and unauthorized personnel. These are the personnel requirements for Ex-approved products in potentially explosive atmospheres:

- All users must know about the risks of electric current and the chemical and physical characteristics of the gas and/or vapor present in hazardous areas.
- The installation for Ex-approved products must be made in conformity to the international or national standards (IEC/EN 60079-17).

Product approval standards

Intrinsic Safe standards

North America USA and Canada certifications

Standards tested to:

UL 913
UL 60079-0,
UL 60079-11,
CSA-C22.2 No. 157-92
CSA-C22.2 No. 60079-0:11,
CSA-C22.2 No. 60079-11:14,

Markings for North America

USA:

Class I, II, III; Division 1; Groups C, D, E, F, G
Class I; Zone 0, AEx ia IIB Ga (Groups C & D)

Canada:

Class I, II, III; Division 1; Groups C, D, E, F, G
Ex ia IIB Ga (Groups C & D)



Europe and Worldwide certifications

Standards tested to:

ATEX

EN 60079-0:2012;
EN 60079-11:2012;
EN 60079-26:2007+COR1:2011;
EN 50303:2000

IECEX

IEC 60079-0:2011;
IEC 60079-11:2011;
IEC 60079-26:2006

ATEX & IECEX Markings

Ex ia I Ma
Ex ia IIC T3 Ga
Ex ia IIIC Da T200°C Da

Ambient Temperature: -40°C to +84°C (-40°F to +183°F)

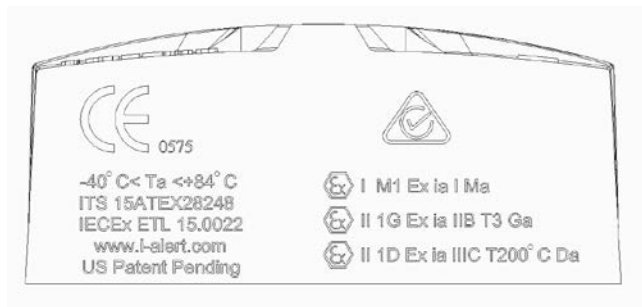

Electromagnetic compatibility certifications

Standards for testing i-ALERT2 Equipment Health Monitor

Radiated Emissions

FCC 47CFR 15 Subpart B:2014,
EN 61000-6-4:2007

Electro-Static Discharge Immunity Test

(EN 61000-4-2:1995 per EN 61000-6-2:2007 +AMD 1 Cor 12)
(EN 61000-4-2:2009 per ETSI EN 301 489-1 V1.9.2

Radiated, Radio-Frequency, Electromagnetic Immunity

(EN 61000-4-3:2002 per EN 61000-6-2:2007 +AMD 1 Cor 12)
(EN 61000-4-3:2006+A1:2008+A2:2010 per ETSI EN 301 489-1 V1.9.2

Power Frequency Magnetic Field Immunity Test

(EN 61000-4-8 1993 per EN 61000-6-2:2007 +AMD 1 Cor 12)

Standards for testing Bluetooth radio

Industry Canada, Interference-Causing Equipment Standard for Information Technology Equipment (ITE).

ICES-003 Issue 5 August 2012,

Electromagnetic compatibility (EMC). Generic standards. Immunity for industrial environments

CENELEC EN 61000-6-2:2007 +AMD 1 Cor 12,

Electromagnetic compatibility (EMC) Generic standards - Emission standard for industrial environments

CENELEC EN 61000-6-4:2007,

ElectroMagnetic Compatibility (EMC) standard for radio equipment and services;

Part 1: Common technical requirements

ETSI EN 301 489-1 V1.9.2 (2011-09),

ElectroMagnetic Compatibility (EMC) standard for radio equipment;

Part 17: Specific conditions for Broadband Data Transmission Systems

ETSI EN 301 489-17 V2.2.1 (2012-09)

FCC REGULATORY INFORMATION

The FCC identifier for the radio module contained in the i-Alert2 device is **FCC ID: T7VPAN17**.

The radio module in the i-Alert2 device meets the requirements for modular transmitter approval as detailed in FCC public Notice DA00-1407.transmitter

Operation is subject to the following two conditions: (1) This device may not cause harmful interference, and (2) This device must accept any interference received, including interference that may cause undesired operation.

The FCC requires the user to be notified that any changes or modifications made to this device that are not expressly approved by ITT may void the user's authority to operate the equipment.

This equipment has been tested and found to comply with the limits for a Class B digital device, pursuant to Part 15 of the FCC Rules. These limits are designed to provide reasonable protection against harmful interference in a residential installation. This equipment generates, uses and can radiate radio frequency energy and, if not installed and used in accordance with the instructions, may cause harmful interference to radio communications.

However, there is no guarantee that interference will not occur in a particular installation. If this equipment does cause harmful interference to radio or television reception, which can be determined by turning the equipment off and on, the user is encouraged to try to correct the interference by one or more of the following measures:

- Reorient or relocate the receiving antenna.
- Increase the separation between the equipment and receiver.

-
- Connect the equipment into an outlet on a circuit different from that to which the receiver is connected.
 - Consult the dealer or an experienced radio/TV technician for help

RF EXPOSURE

To comply with FCC RF Exposure requirements, do not modify, remove or change the antenna on the radio module contained within the i-Alert2 device.

The radiated output power of the radio with mounted ceramic antenna (**FCC ID: T7VPAN17**) is far below the FCC radio frequency exposure limits. Nevertheless, the radio shall be used in such a manner that the potential for human contact during normal operation is minimized.

INDUSTRY CANADA CERTIFICATION

The radio module contained in the i-Alert2 device is licensed to meet the regulatory requirements of Industry Canada (IC), license: **IC: 216Q-PAN17**.

IC NOTICE

The radio module within the i-Alert2 device complies with Canada RSS-GEN Rules. The device meets the requirements for modular transmitter approval as detailed in RSS-GEN.

Operation is subject to the following two conditions: (1) This device may not cause harmful interference, and (2) This device must accept any interference received, including interference that may cause undesired operation.

EUROPEAN R&TTE DECLARATION OF CONFORMITY

The Bluetooth module contained within the i-Alert2 device is in compliance with the essential requirements and other relevant provisions of Directive 1999/5/EC. As a result of the conformity assessment procedure described in Annex III of the Directive 1999/5/EC.

The i-Alert2 device can be used in the following countries: Austria, Belgium, Cyprus, Czech Republic, Denmark, Estonia, Finland, France, Germany, Greece, Hungary, Ireland, Italy, Latvia, Lithuania, Luxembourg, Malta, Poland, Portugal, Slovakia, Slovenia, Spain, Sweden, The Netherlands, the United Kingdom, Switzerland, and Norway.

Product Description

General description i-ALERT2 Condition Monitor

Description

The i-ALERT2 Equipment Health Monitor is a compact, battery-operated monitoring device that continuously measures the vibration and temperature of the pump. The i-ALERT2 Equipment Health Monitor uses blinking red LED and wireless notification to alert the pump operator when the pump exceeds vibration and temperature limits. This allows the pump operator to make changes to the process or the pump before catastrophic failure occurs. The Equipment Health Monitor is also equipped with a single green LED to indicate when it is operational and has sufficient battery life.

The i-ALERT2 Equipment Health Monitor also contains a Bluetooth radio that communicates to certain Bluetooth 4.0 equipped devices through a mobile application. Data is shared between the i-ALERT2 Equipment Health Monitor, the mobile application, phone, and the data servers.

The i-ALERT2 Equipment Health Monitor will communicate sensor related data (such as vibration, temperature, runtime information, and device statistics) stored in the device to the mobile application. The mobile application will send commands to the device.

The Mobile application will back up device data as well as app usage information on the data servers.

The data servers will send the mobile application equipment technical data.

For full details about data storage and rights please review the Privacy Policy.

Alarm mode

The i-ALERT2 Equipment Health Monitor enters alarm mode when either vibration or temperature limits are exceeded over two consecutive readings within a 10 minute period. Alarm mode is indicated with 1 (one) red flashing LED within 2 (two) second intervals.

Warning and Alarm Values

Variable	Limit
Temperature (default)	80°C (176°F)
Vibration Alarm (0.1-1.5 ips)	100% increase over the baseline level
Vibration Warning (0.1-1.5 ips)	75% increase over the baseline level

Battery life

The i-ALERT2 Equipment Health Monitor battery is not replaceable. You must replace the entire unit once the battery runs out of power. The battery life is not covered as part of the standard 5-year pump warranty.

The following determines the “normal operating conditions” in which the 3 year battery life is determined:

- Temperature: 18°C (65°F)
- Dashboard connections (including trend download): Once per day
- FFT and Time Waveform usage: One tri-axial request per 14 days
- Operation time in Alarm: 25% of time

Installation

Attach the i-ALERT2 Equipment Health Monitor to the pump

CAUTION:

Always wear protective gloves. The equipment and the i-ALERT2 device can be hot.

Mounting Options

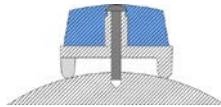
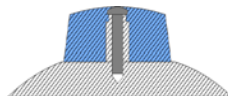
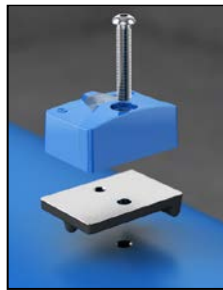

Mill a Slot	Drill and Tap	Epoxy ¹
Screw: ¼-28 x 1.125in	Screw: ¼-28 x 1.5in	Screw: ¼-28 x 1.125in
Slot: 2.25in L x 1.6in W	Tap: ¼-28 UNF x ¼in deep	Epoxy: application specific
Temperature: ****	Temperature: ***	Temperature: **
Vibration: ****	Vibration: ***	Vibration: ***
Prep Time: **	Prep Time: ***	Prep Time: ****

Epoxy¹ – Not included

Epoxy recommendations: depends on applications
Location recommendations: over bearing, LEDS in line with shaft. Secure.
If only one is on recommend to be on drive end
Torque spec and allen wrench size.
Installation videos visit i-ALERT.com

App download?
Register account with email

Commissioning, Startup, Operation and Shutdown

Activate the i-ALERT2 Equipment Health Monitor



Steps to activate the i-ALERT2 \ Equipment Health Monitor:

1. Remove the sticker.
2. The i-ALERT2 will look for light.
Note: If in a dark environment use light source to activate.
3. When activated a sequence of flashing LEDs will start to indicate that the unit is powered on.
4. When sequence is completed the green LED will flash every 5 sec under normal operating conditions



WARNING:

Never heat the condition monitor to temperatures in excess of 140°C (284°F). Heating to these temperatures could result in death or serious injury.

CAUTION:

Always wear protective gloves. The equipment and condition monitor can be hot.

Reset the i-ALERT2 Equipment Health Monitor

To reset the i-ALERT2 Equipment Health Monitor

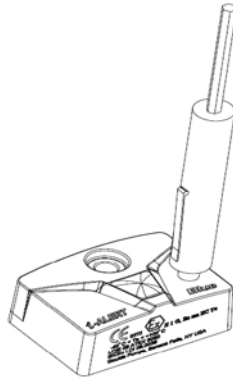

New Chart

Action	LED	Action performed if magnet is removed	System Action performed if magnet is removed
Apply Magnet over Bluetooth Symbol For 1 second	Red LED active	Red LED active	Nothing
Magnet held in place for additional 2 seconds.	Blue LED active	Red LED Flash: Bluetooth OFF Green LED Flash: Bluetooth ON	Bluetooth radio On/Off toggle
Magnet held in place for additional 4 seconds	LEDs cycle through all colors	All Three LEDs will Flash and turn OFF	Unit RESETS when LEDs stop Flashing

i-ALERT2 Equipment Health Monitor routine operation

Measurement interval

The measurement interval for the condition monitor during normal and alarm operation is 5 minutes.

When the monitor measures a reading beyond the specified temperature and vibration limits, the appropriate red LED flashes (after 2 consecutive readings). After the process or pump condition that causes the alarm is corrected, the condition monitor returns to normal mode after one normal-level measurement.

Alarm mode

The condition monitor's alarm mode is activated after two consecutive readings. When the alarm mode is on, you should investigate the cause of the condition and make necessary corrections in a timely manner.

Magnetic device considerations

Be careful when you use magnetic devices in close proximity of the condition monitor, such as magnetic vibration-monitoring probes or dial indicators. These magnetic devices can accidentally activate or deactivate the condition monitor resulting in improper alarm levels or loss of monitoring.

Wireless Integration

A Bluetooth Low Energy Radio is utilized to communicate condition monitoring information to a mobile Smart device that the operator can easily view and react to.

Maintenance

Guidelines for i-ALERT2 Equipment Health Monitor disposal

Precautions



WARNING:

- Never heat the condition monitor to temperatures in excess of 284°F (140°C). Heating to these temperatures could result in death or serious injury.
- Never dispose of the condition monitor in a fire. This could result in death or serious injury.

Guidelines

This Product Contains Lithium Thionyl Chloride therefore the local Waste management companies can provide assistance in the disposal of the device that contain this type of battery.

Troubleshooting

i-ALERT2 Equipment Health Monitor troubleshooting

Symptom	Cause	Remedy
There are no red, green, or blue flashing LED	The battery is dead.	Replace the equipment health monitor.
	The unit is in sleep mode.	Activate the condition monitor using magnet.
	The unit is malfunctioning.	Consult your ITT representative for a warranty replacement.
The red LED is flashing, but the temperature and vibration are at acceptable levels.	The baseline is too low.	Check the temperature and vibration levels and request new baseline. Or manually change alarm limits.
	The unit is malfunctioning.	Consult your ITT representative for a warranty replacement.

For connection issues with smart devices, please visit www.i-ALERT.com

For ITT's privacy Policy, click here: <http://itt.com/privacy/>

For ITT's terms and conditions, click here: NEEDS URL

For User SW License Agreement, click here: NEEDS URL

Notes

Visit our website for the latest version of this document and more information:

www.i-alert2.com



ENGINEERED FOR LIFE

Goulds Pumps
240 Fall Street
Seneca Falls, NY 13148
USA
Tel. 1-800-446-8537
Fax (315) 568-2418

IOM-i-ALERT2-EN-Sep 2015