



# PPC

*Mechanical Seals*

**ULTRA Seal 2000**  
*Environmentally Safe Double/Tandem  
Metal Bellows Cartridge Seal*



*Solutions to Mechanical  
Seal Problems*

THROUGH CREATIVE ENGINEERING AND EXPERT TECHNICAL SERVICE

# METAL BELLOWS SEAL RELIABILITY

## • BELLOWS DESIGN

*provides even pressure to hold seal faces together. Flexibility automatically compensates for axial movement or runout.*

## • SELF-CLEANING ACTION

*due to centrifugal force throwing suspended solids away from the bellows.*

## • NO SPRINGS

*to clog or corrode.*

## • STATIC O-RINGS

*eliminate fretting and shaft wear.*

# OFF-THE-SHELF CARTRIDGE DESIGN

## • PRESET

*virtually eliminating installation errors. Installs in minutes.*

## • FITS POPULAR ANSI PUMPS

*and others without modifications to the stuffing box. The UltraSeal 2000 is designed to handle temperatures up to 450°F and pressures up to 300 PSI.*

### MATERIALS OF CONSTRUCTION

METAL PARTS	ELASTOMERS	INBOARD SEAL FACES	OUTBOARD SEAL FACES
316 Stainless Steel with Hastelloy-C* Bellows	EPDM AFLAS** Fluoro-or Perfluoro- Elastomers	Carbon or Tungsten Carbide Rotary  Silicon Carbide Stationary	Carbon Rotary  Silicon Carbide Stationary

\* Haynes International, Inc. T.M.

\*\* Asahi Glass Co., LTD. Reg TM.

# ULTRASeal 2000

DOUBLE/TANDEM METAL BELLOWS SEAL

Designed and built to exceed EPA Regulations and eliminate fugitive emissions



### IMPROVED CIRCULATION

*due to tangential fluid outlet.*

### OUTBOARD SEAL RUNS COOLER

*due to unique bellows design.*

### INBOARD SEAL FACES REMAIN CLOSED

*even when barrier fluid pressure is lost.*

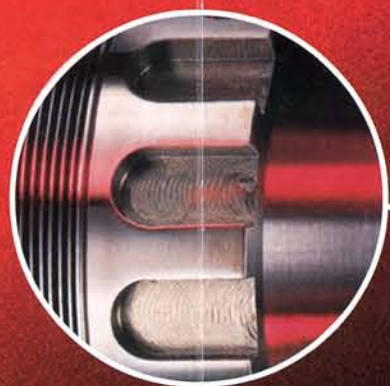

### PUMPING SLOTS PROVIDE FORCED FLOW FOR MAXIMUM COOLING

*eliminating reliance on thermal syphon and allowing the use of most clean barrier fluids.*

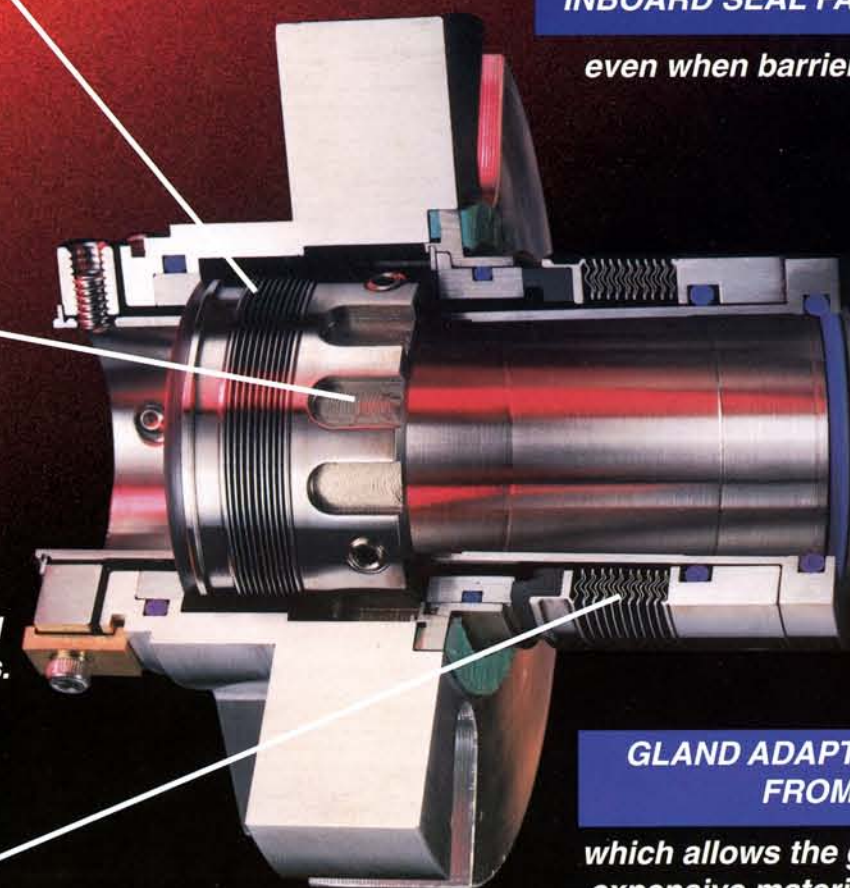

### GLAND ADAPTER KEEPS PRODUCT FROM THE GLAND

*which allows the gland to be made of less expensive materials. The gland is not exposed to the more severe conditions.*

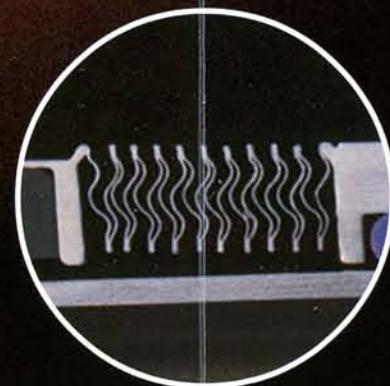

### GREATER DIFFERENTIAL BARRIER FLUID PRESSURES

*are possible due to special balance on the inboard seal. This allows U2000 to operate as a double or tandem seal and run cooler at higher pressure.*

### ENHANCED BELLOWS STRENGTH

*due to double ripple nested design.*

### SLOTTED GLAND FITS POPULAR ANSI PUMPS

*and other pumps without modification to the stuffing box. (See back page for detailed listings.)*



# ULTRASEAL 2000

DOUBLE/TANDEM METAL BELLOWS SEAL

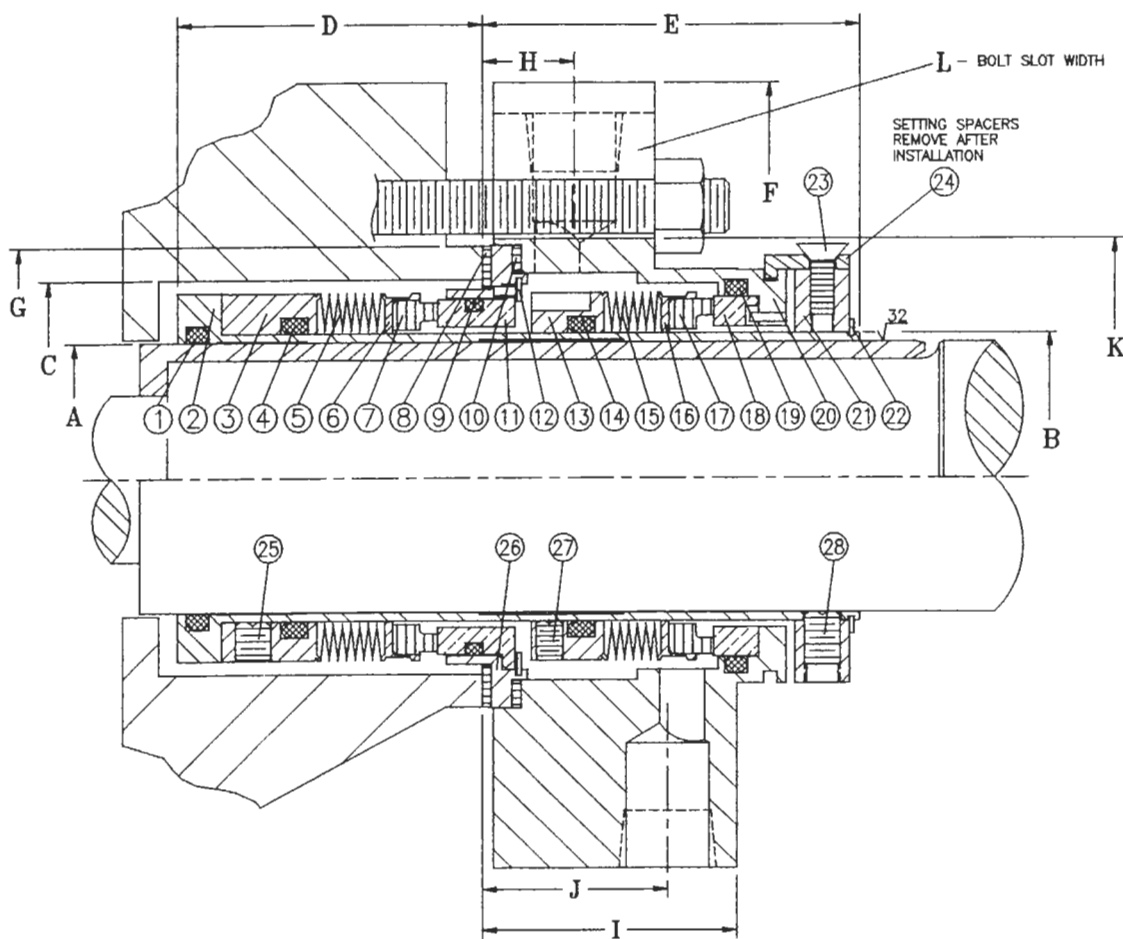

- 1 O-RING
- 2 SLEEVE
- 3 BELLOWS COLLAR
- 4 O-RING
- 5 BELLOWS
- 6 INSERT COLLAR
- 7 INSERT
- 8 GASKET
- 9 O-RING
- 10 GASKET
- 11 INBOARD SEAT
- 12 SPIROLOX
- 13 BELLOWS COLLAR
- 14 O-RING
- 15 BELLOWS
- 16 INSERT HOLDER
- 17 INSERT
- 18 OUTBOARD SEAT
- 19 O-RING
- 20 GLAND
- 21 SLEEVE COLLAR
- 22 SPIROLOX
- 23 FLAT HEAD SET SCREWS
- 24 SETTING SPACERS
- 25 SET SCREWS
- 26 GLAND ADAPTER
- 27 SET SCREWS
- 28 SET SCREWS

A	B	C min	C max	D	E	F	G	H	I	J	K	L
1.125	1.250	1.750	1.812	1.62	1.89	3.75	2.250	.92 ANGLD	1.22	.92 ANGLD	2.437	.44
1.375	1.500	2.000	2.030	1.62	1.89	4.00	2.395	.92 ANGLD	1.22	.92 ANGLD	2.750	.44
1.500	1.625	2.250	2.437	2.06	2.62	4.48	2.688	.64	1.75	1.29	2.875	.44
1.625	1.750	2.375	2.562	2.06	2.62	4.98	2.812	.64	1.75	1.29	3.015	.56
1.750	1.875	2.500	2.812	2.12	2.62	5.48	3.020	.64	1.75	1.29	3.170	.56
1.875	2.000	2.625	2.937	2.12	2.62	5.48	3.125	.64	1.75	1.29	3.312	.56
2.000	2.125	2.750	3.187	2.12	2.62	5.48	3.437	.64	1.75	1.29	3.531	.56
2.125	2.250	2.875	3.437	2.12	2.62	5.98	3.688	.64	1.75	1.29	3.781	.69
2.250	2.375	3.000	3.562	2.12	2.62	5.98	3.812	.64	1.75	1.29	3.920	.69
2.500	2.625	3.375	3.812	2.19	2.62	6.48	4.062	.64	1.75	1.29	4.141	.69
2.625	2.750	3.500	3.937	2.19	2.62	6.48	4.187	.64	1.75	1.29	4.312	.69

### WARRANTY

PPC seals and parts are guaranteed to be free from defects in material and workmanship and are guaranteed to render satisfactory service when used for the purpose for which they are designed.

